

ISSUE DATE NOVEMBER 1st, 2011



SECTION 3

GRAVITY SEWER

Page List	
Page Number	Page Title
COVER	COVER
GS-01	STANDARD PRECST MANHOLE
GS-02	SHALLOW PRECAST MANHOLE
GS-03	OUTSIDE DROP MANHOLE
GS-04	CONNECTIONS TO EXISTING MANHOLE
GS-05	INSIDE DROP CONNECTION
GS-06	GRAVITY SEWER CUT-IN WYE & SERVICE
GS-07	OPTIONAL GRAVITY SEWER WYE CUT-IN
GS-08	TYPICAL SEWER SERVICE
GS-09	TYPICAL RESIDENTIAL SEWER SERVICE WITH RISER
GS-10	TYPICAL CLEAN-OUT
GS-11	TEMPORARY TERMINAL CLEAN-OUT
GS-12	MANHOLE RING AND COVER
GS-13	HINGERD MANHOLE RING AND COVER
GS-14	GREASE INTERCEPTOR TANK
GS-15	GREASE INTERCEPTOR VOLUME REQ.

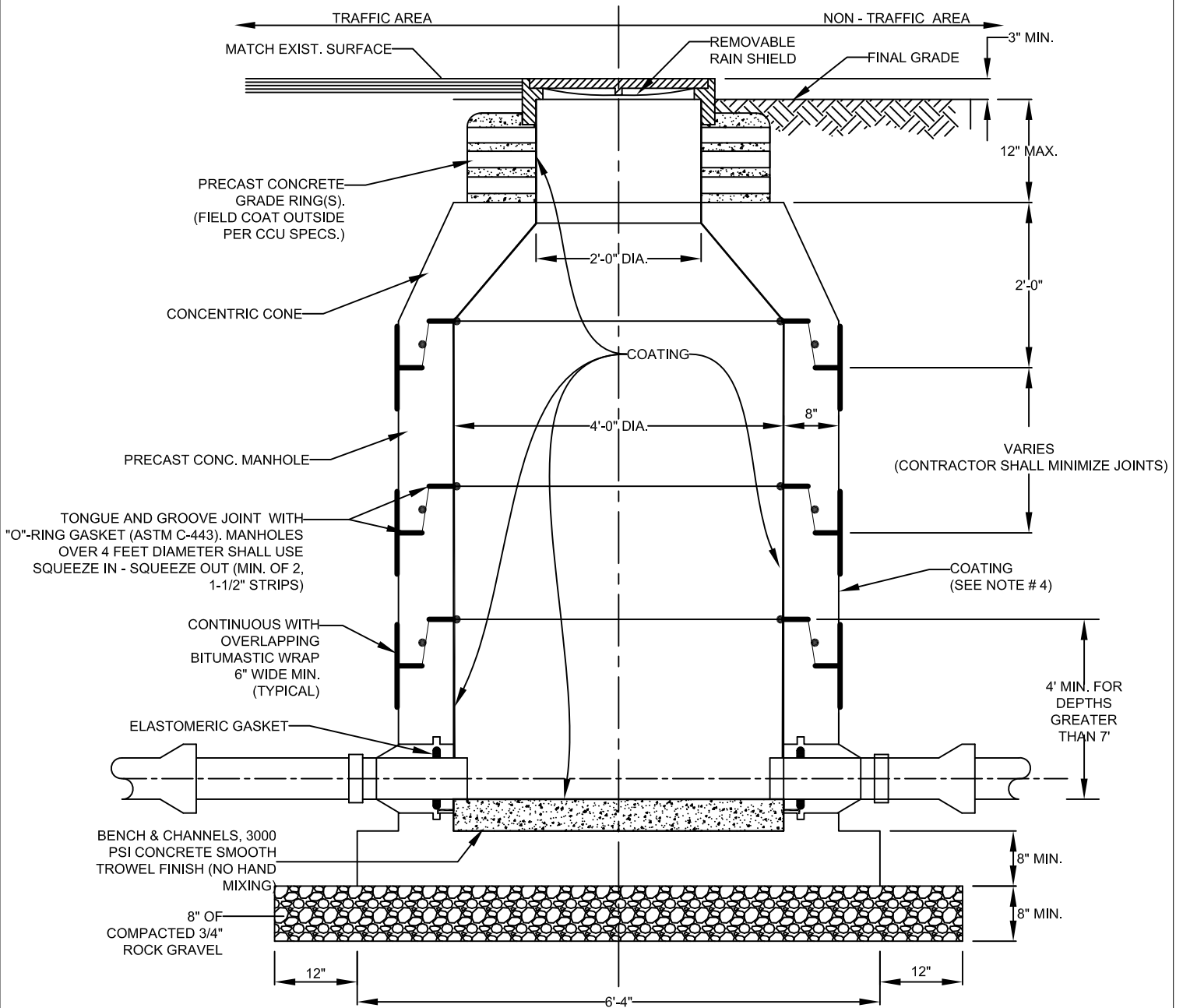

NOTE:

1. PROVIDE 1% SLOPE THROUGH MANHOLE.

Z:\Auto Cad R14\DETAILS\2012 Details\03.GRAVITY SEWER\GS-01-PCMH.dwg

DATE: 11/01/2011
DRAWN BY: DEC
APPROVED BY: BRB

STANDARD PRECAST MANHOLE

CHARLOTTE COUNTY UTILITIES

PROVIDED FOR INFORMATIONAL PURPOSES ONLY. NO MODIFICATIONS WITHOUT WRITTEN CCU APPROVAL.
GS-01
ID: GS-01-PCMH.DWG

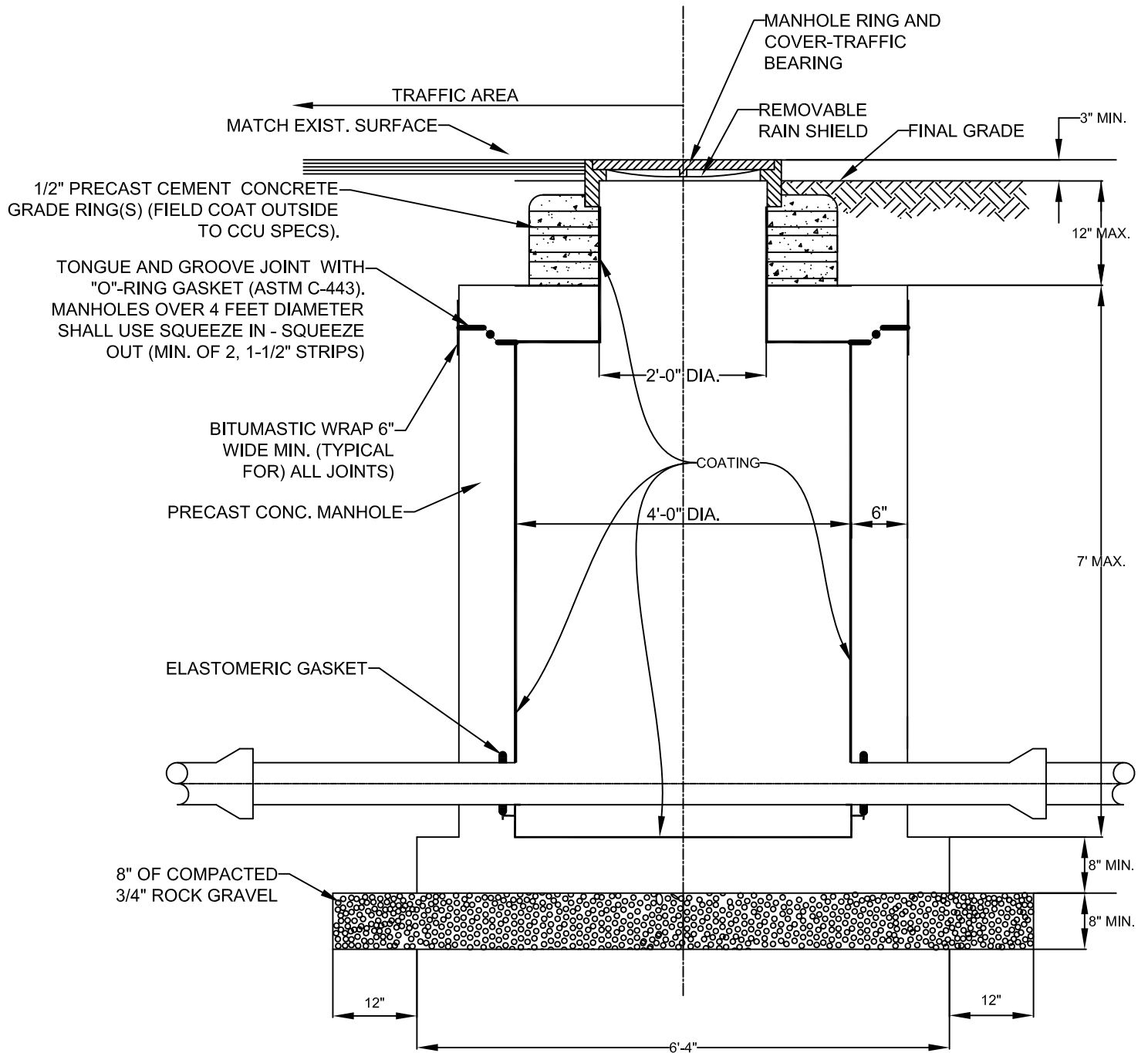

NOTE:

1. PROVIDE 1% SLOPE THROUGH MANHOLE.

Z:\Auto Cad R14\DETAILS\2012 Details\03.GRAVITY SEWER\GS-02-SPCMH.dwg

DATE: 11/01/2011
DRAWN BY: DEC
APPROVED BY: BRB

SHALLOW PRECAST MANHOLE

CHARLOTTE COUNTY UTILITIES

PROVIDED FOR INFORMATIONAL PURPOSES ONLY. NO MODIFICATIONS WITHOUT WRITTEN CCU APPROVAL.
GS-02
ID: GS-02-SPCMH.dwg

4 - #4 REBAR TO BE EQUALLY SPACED AROUND DROP AND A MIN. OF 3" FROM ALL SIDES. TIE TO EXISTING REBAR IN BOTTOM SECTION. (MIN. 4 REBAR)

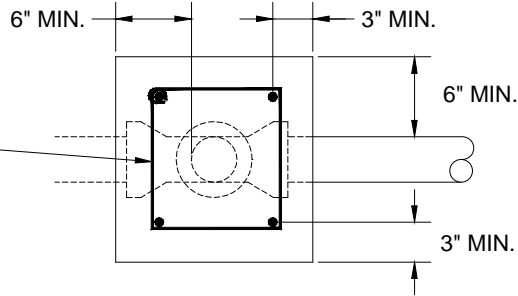

REBAR PLACEMENT DETAIL

ELASTOMERIC GASKET WITH LINERS

COATING PER CCU SPECS.

ELASTOMERIC GASKET WITH LINERS

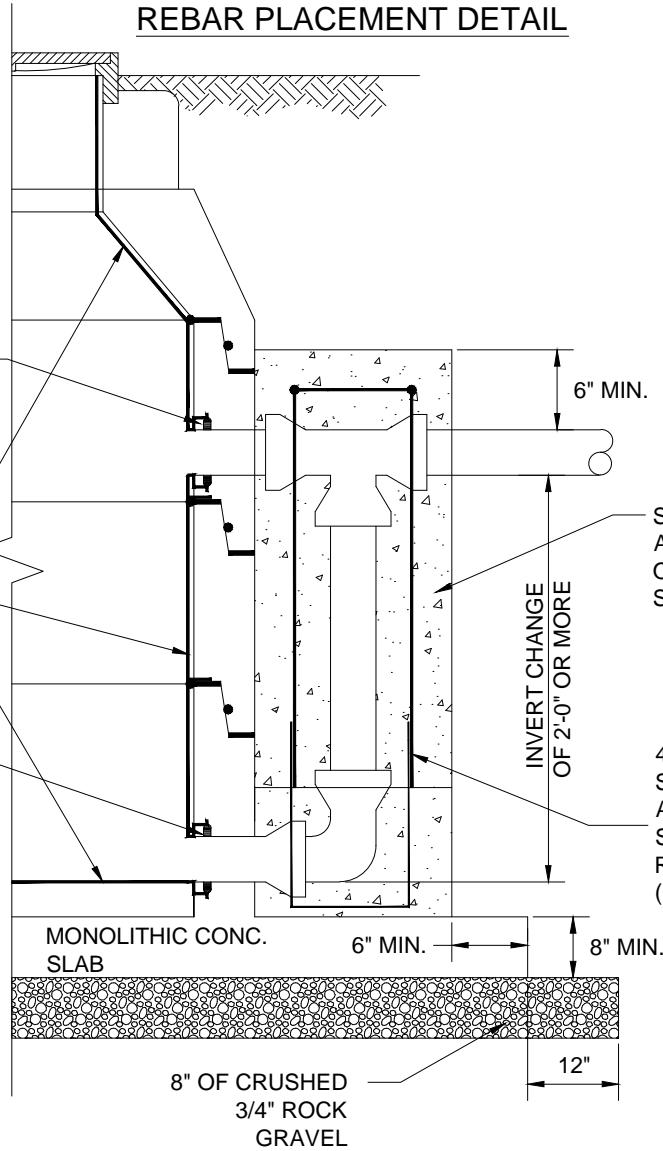

SURROUND DROP PIPE WITH A MINIMUM OF 6" CONCRETE ON ALL SIDES. CONCRETE SHALL BE 3000 PSI.

4 - #4 REBAR TO BE EQUALLY SPACED AROUND DROP AND A MIN. OF 3" FROM ALL SIDES. TIE TO EXISTING REBAR IN BOTTOM SECTION. (MIN. 4 REBAR)

NOTE:

1. PROVIDE 1% SLOPE THROUGH MANHOLE.

DATE: 11/01/2011

DRAWN BY: DEC

APPROVED BY: BRB

OUTSIDE DROP MANHOLE

CHARLOTTE COUNTY UTILITIES

PROVIDED FOR INFORMATIONAL PURPOSES ONLY. NO MODIFICATIONS WITHOUT WRITTEN CCU APPROVAL.

GS-03

ID: GS-03-OSDMH.dwg

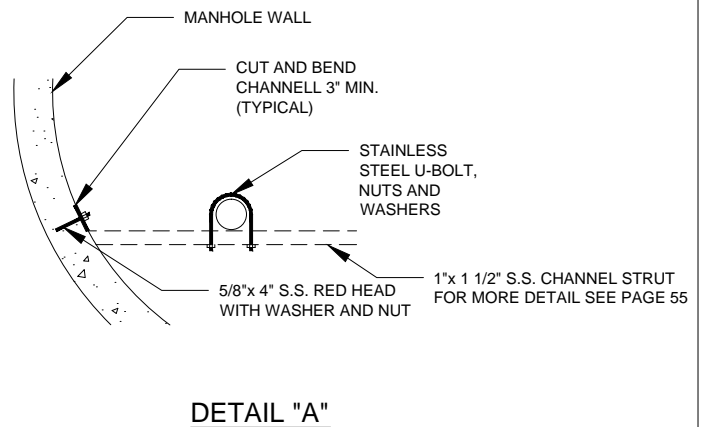
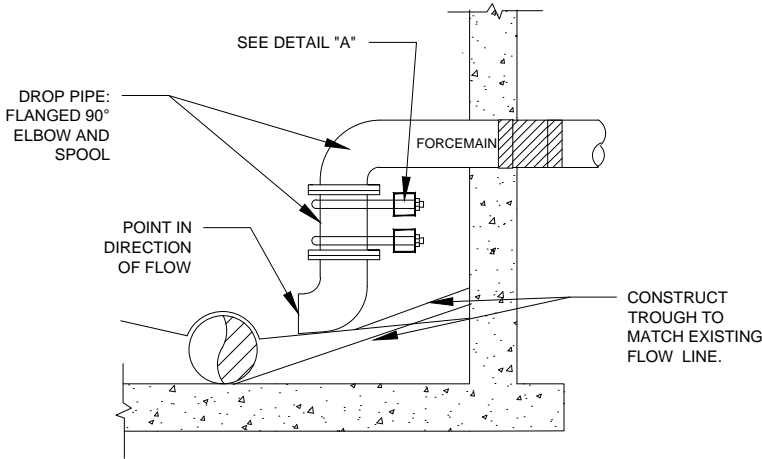

FORCEMAIN & LOW PRESSURE CONNECTION

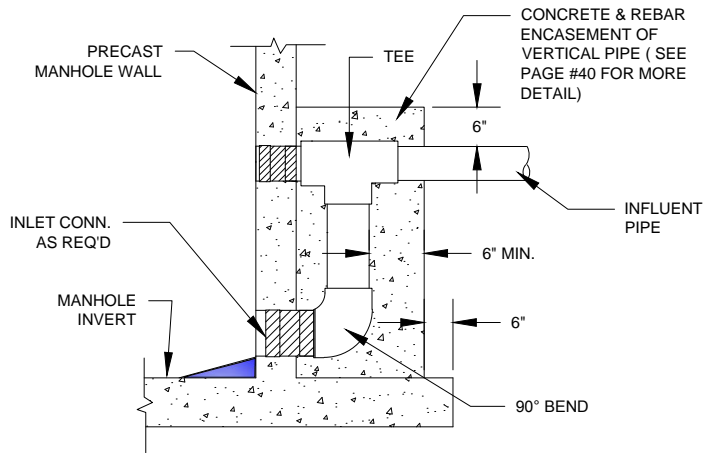
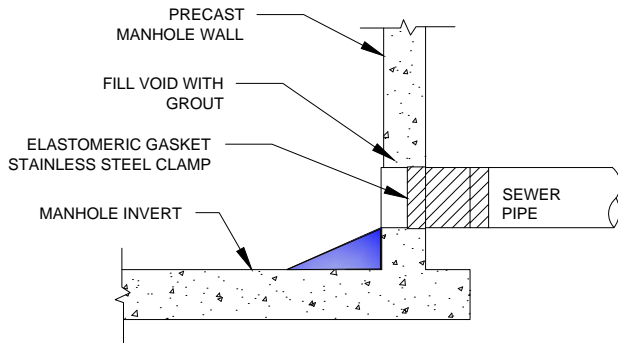

TYPICAL CONNECTION

DROP CONNECTION

NOTES:

1. PENETRATIONS TO EXISTING MANHOLES SHALL BE CORE BORED, AND ELASTOMERIC GASKET WITH STAINLESS STEEL PIPE CLAMP SHALL BE INSTALLED.
2. DROP CONNECTION SHALL BE REQUIRED WHENEVER THE INVERT OF AN INFLUENT SEWER IS LOCATED TWO (2) OR MORE FEET ABOVE THE MAIN CHANNEL.
3. DROP PIPE SHALL BE OF EQUAL SIZE AS THE INFLUENT SEWER. DROP PIPE SHALL BE PVC WITH STAINLESS STEEL FITTINGS. IF A TRANSITION TO OTHER TYPE OF PIPE, THE TRANSITION SHALL BE OUTSIDE OF MANHOLE.

DATE: 11/01/2011

DRAWN BY: DEC

APPROVED BY: BRB

CONNECTIONS TO EXISTING MANHOLE

CHARLOTTE COUNTY UTILITIES

PROVIDED FOR INFORMATIONAL PURPOSES ONLY.
NO MODIFICATIONS WITHOUT WRITTEN CCU APPROVAL.

GS-02

ID: GS-04-MHCON.dwg

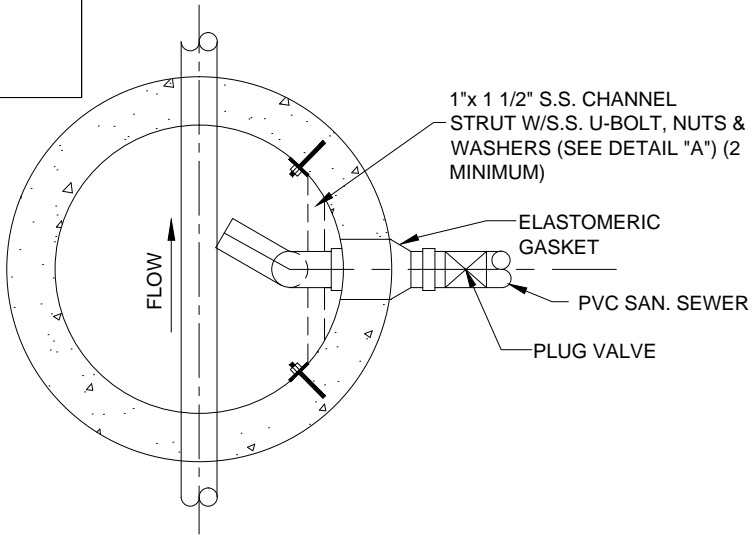
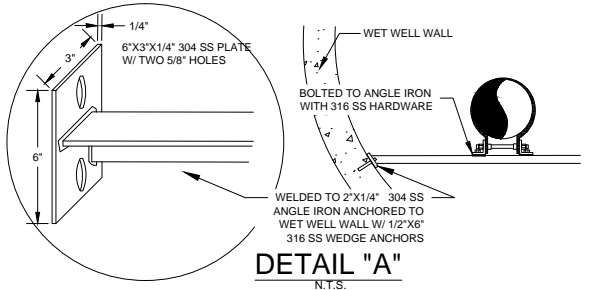

TOP VIEW

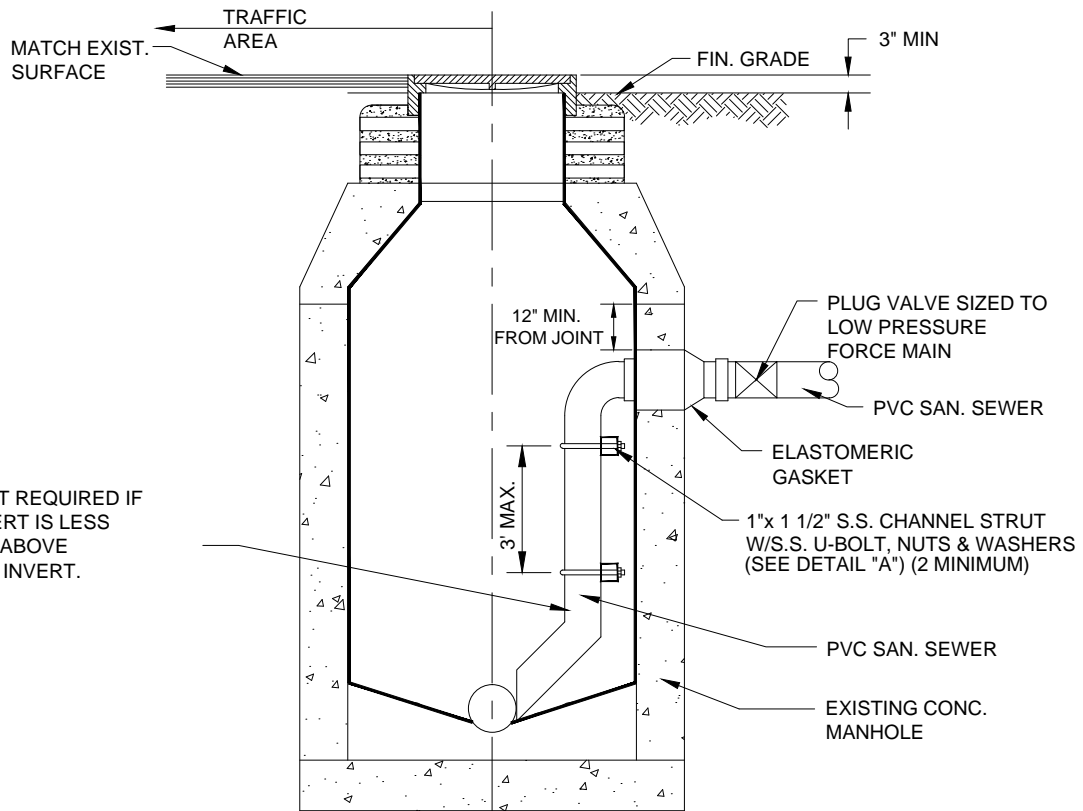

PROFILE VIEW

DATE: 11/01/2011

DRAWN BY: DEC

APPROVED BY: BRB

INSIDE DROP MANHOLE

CHARLOTTE COUNTY UTILITIES

PROVIDED FOR INFORMATIONAL
PURPOSES ONLY.
NO MODIFICATIONS WITHOUT
WRITTEN CCU APPROVAL.

GS-05

ID: GS-05-ISD-PCMH.dwg

NOTES:

1. ALL P.V.C. SANITARY GRAVITY SEWER PIPE SHALL BE:
FOR DEPTHS 0-4 FEET - DR 18 - FOR DEPTHS 4 FEET OR GREATER BURY DEPTH - DR 26
2. SEWER SERVICE SHALL BE INSTALLED AT GRADE OF NOT LESS THAN 1/8" PER FOOT AND NO MORE THAN 1 3/4" PER FOOT

ADJUSTABLE REPAIR COUPLING (ARC) WITH STAINLESS STEEL SHEAR RINGS, CLAMPING BANDS CLAMPS, NUTS AND BOLTS. (2REQUIRED)(TYPICAL)

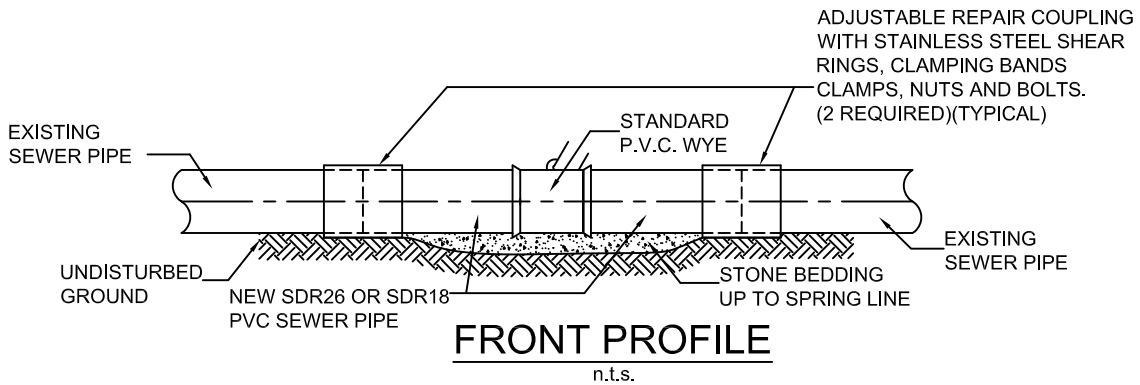
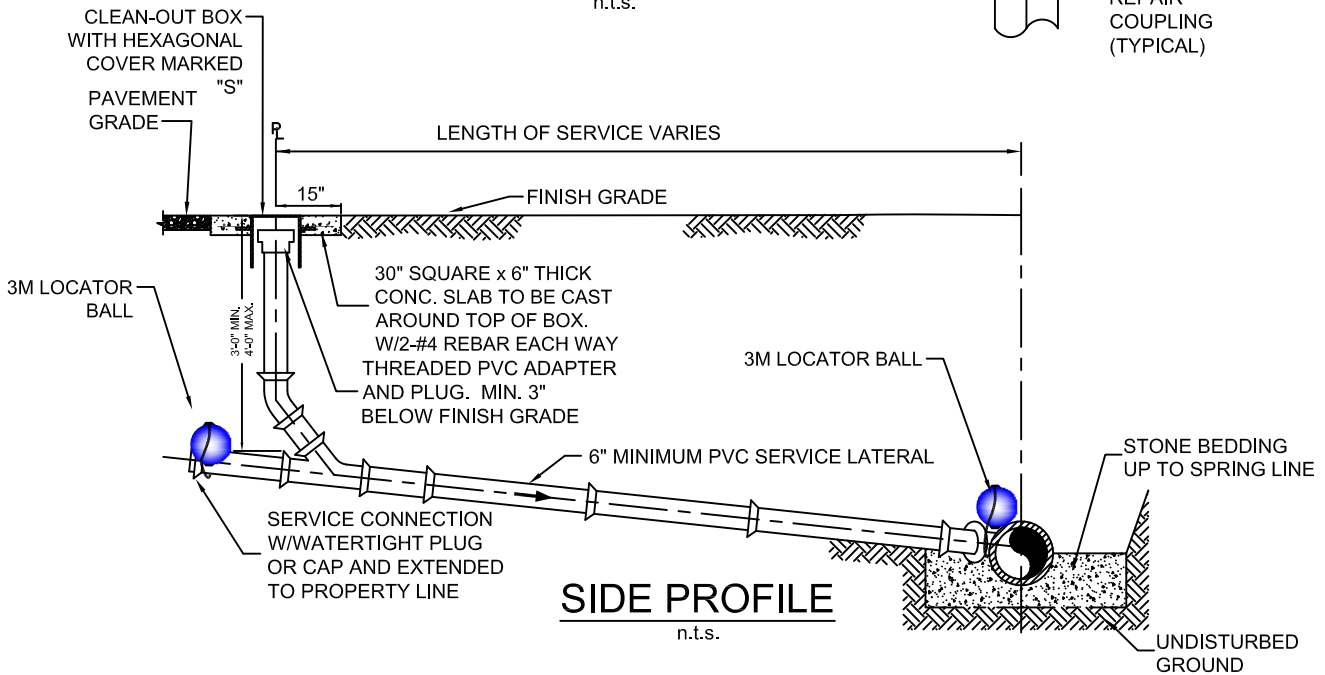
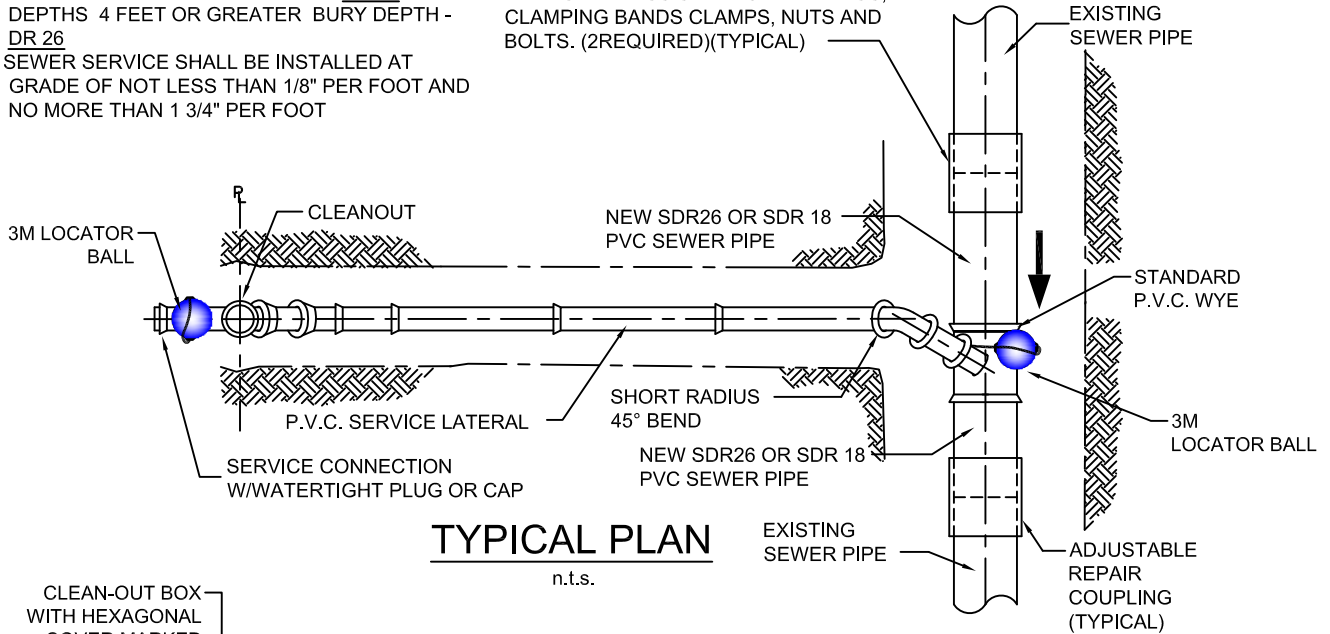

Z:\Auto Cad R14\DETAILS\2012 Details\03.GRAVITY SEWER\GS-06-CIW.dwg

DATE: 11/01/2011

DRAWN BY: DEC

APPROVED BY: BRB

GRAVITY SEWER CUT-IN WYE & SERVICE

CHARLOTTE COUNTY UTILITIES

PROVIDED FOR INFORMATIONAL PURPOSES ONLY. NO MODIFICATIONS WITHOUT WRITTEN CCU APPROVAL.

GS-06

ID: GS-06-CIW.dwg

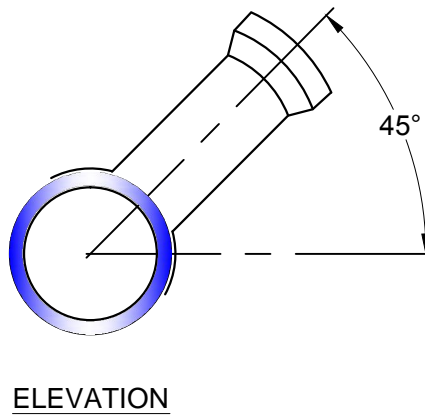
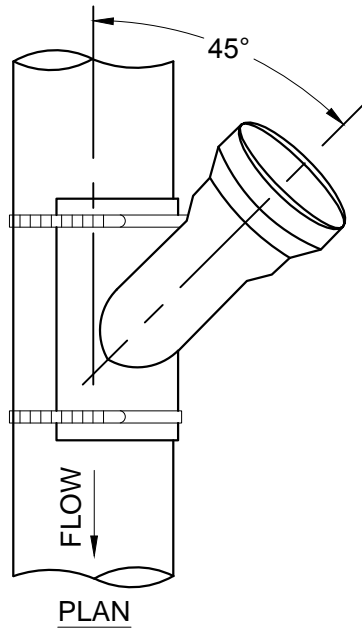

NOTES:

1. CONNECTIONS TO EXISTING SEWER MAINS SHALL BE MADE BY CONTRACTOR IN ACCORDANCE WITH CHARLOTTE COUNTY UTILITIES SPECIFICATIONS.
2. IN NO CASE SHALL CONNECTION BE MADE DIRECTLY ON TOP OF SEWER MAIN.
3. NO MORE THAN ONE CUT IN WYE SHALL BE ALLOWED FOR EACH LENGTH OF SEWER MAIN.
4. TAP SHALL BE MADE AT APPROXIMATELY CENTER OF JOINT LENGTH.
5. THE HOLE FOR THE COLLAR WYE FITTING FOR A SEWER SADDLE SHALL BE MADE WITH A TAPPING MACHINE. THE HOLE SHALL BE CLEANLY MACHINED AND IF NECESSARY WORKED BY HAND WITH A RASP OR SANDED TO ACCOMPLISH A TRUE AND NEAT OPENING FOR THE COLLAR WYE.
6. THE COLLAR WYE SADDLE SHALL BE SECURED TO THE SEWER WITH APPROVED STAINLESS STEEL BANDS.
7. ALL CHIPS, DIRT, EPOXY, MORTAR, AND CONCRETE SHALL BE KEPT OUT OF THE SADDLED SEWER. CLEANING AND BALLING OF THE SADDLED REACH SHALL BE PERFORMED IF REQUIRED BY CCU.
8. ANY DAMAGED PIPE SHALL BE REPAIRED OR REPLACED AS DIRECTED BY CCU.
9. COLLAR WYE SADDLE OR CUT IN WYE TO BE USED WHEN LATERAL IS 4" OR 6" IN DIAMETER. FOR 8" AND OVER, A STANDARD MANHOLE CONNECTION SHALL BE USED.
10. MAIN LINE SHALL BE BROKEN OUT FOR SADDLE ONLY IN THE PRESENCE OF CCU PERSONAL.

DATE: 11/01/2011

DRAWN BY: DEC

APPROVED BY: BRB

**OPTIONAL GRAVITY SEWER
WYE CUT-IN
CHARLOTTE COUNTY UTILITIES**

PROVIDED FOR INFORMATIONAL
PURPOSES ONLY.
NO MODIFICATIONS WITHOUT
WRITTEN CCU APPROVAL.

GS-07

ID: GS-07-OCI.dwg

DATE: 11/01/2011

DRAWN BY: DEC

APPROVED BY: BRB

TYPICAL SEWER SERVICE

CHARLOTTE COUNTY UTILITIES

PROVIDED FOR INFORMATIONAL PURPOSES ONLY. NO MODIFICATIONS WITHOUT WRITTEN CCU APPROVAL.

GS-08

ID: GS-08-TSS.dwg

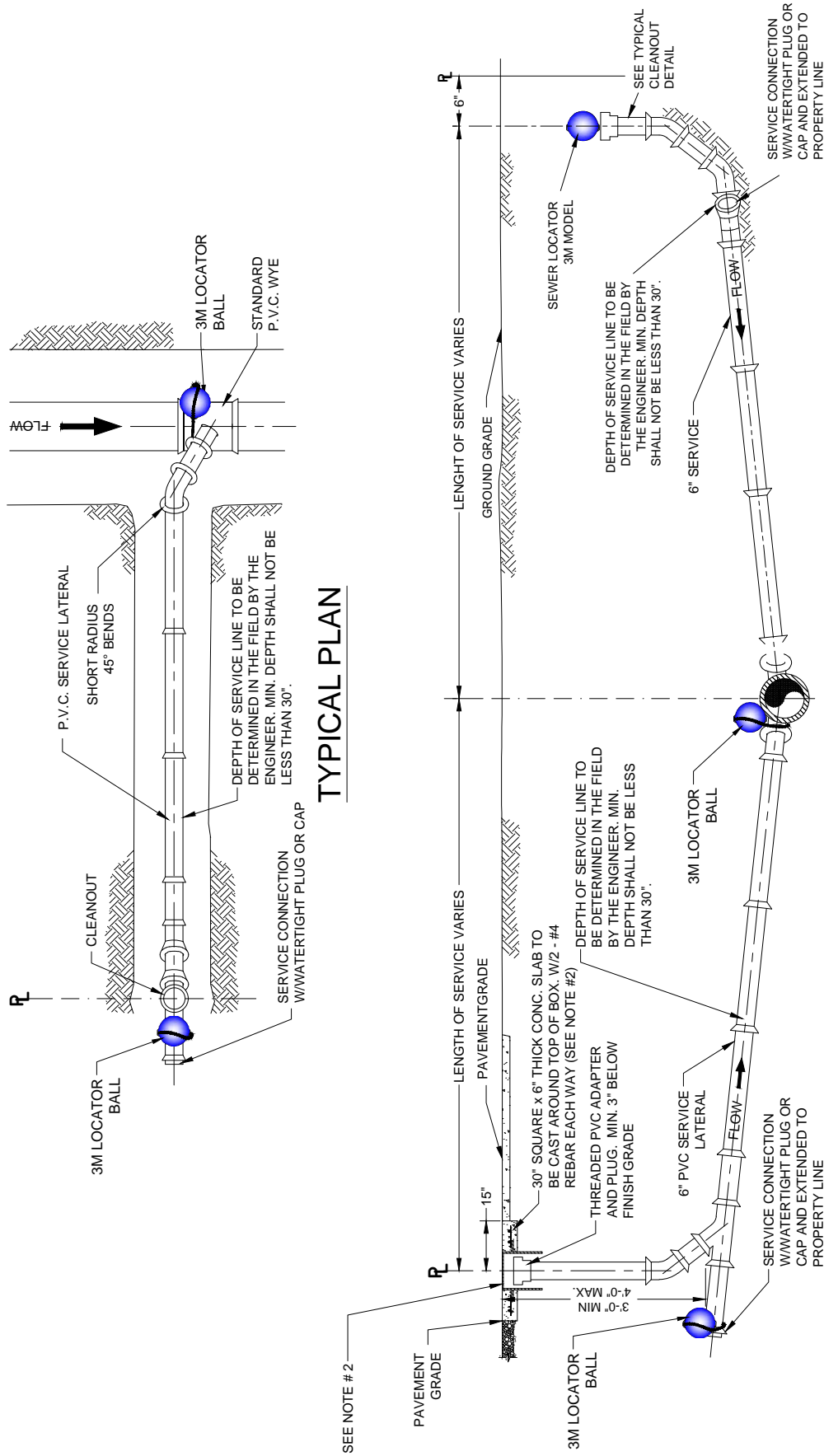

TYPICAL SECTION

- NOTE:
1. ALL P.V.C. SANITARY GRAVITY SEWER PIPE SHALL BE:
 - 1.a. FOR DEPTHS BETWEEN 0-4 FEET - DR 18
 - 1.b. FOR DEPTHS 4 FEET OR GREATER BURY DEPTH - DR 26
 - 1.c. SEWER SERVICE SHALL BE INSTALLED AT GRADE OF NOT LESS THAN 1/8" PER FOOT AND NO MORE THAN 1 3/4" PER FOOT
 - 1.c. GASKETED FITTINGS SHALL BE SAME AS OR GREATER THAN GRADE OF PIPE.
 2. CLEAN-OUT BOX WITH HEXAGONAL COVER MARKED "S"

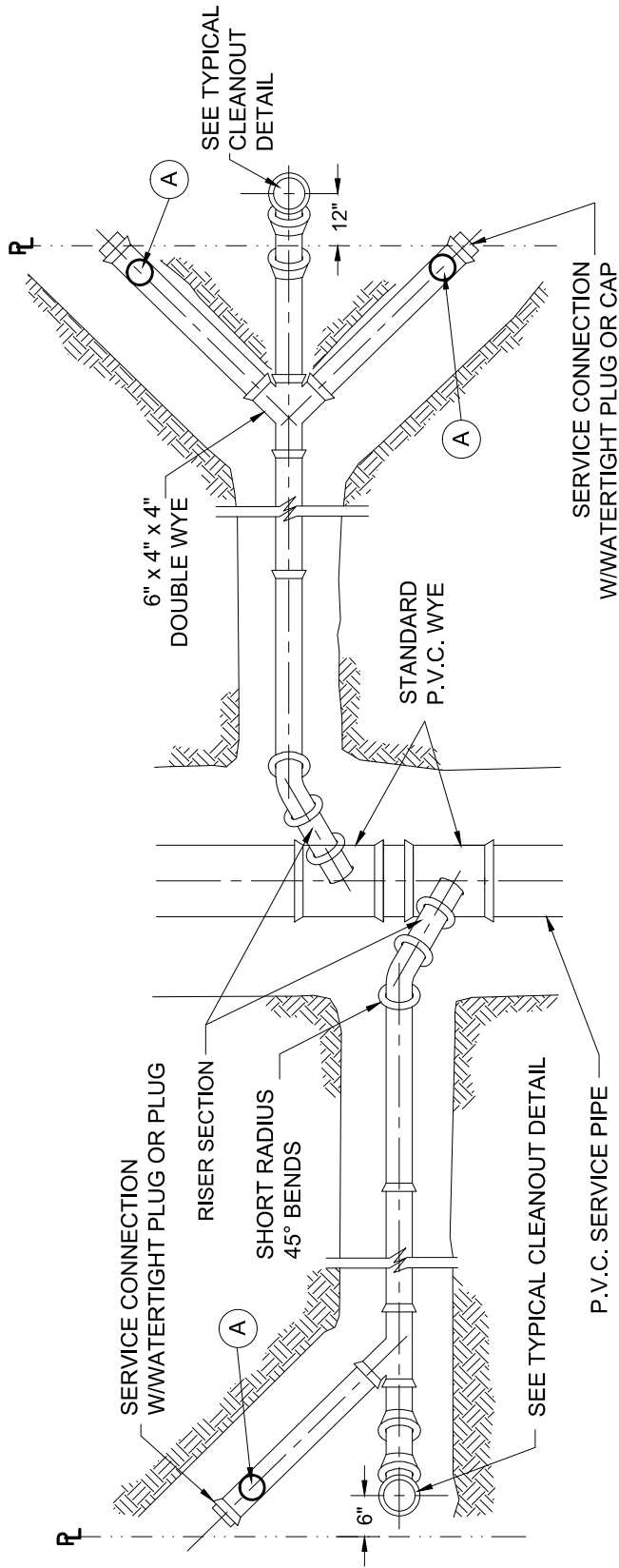

A ELECTRONIC MARKERS SHALL REMAIN IN POSITION AFTER THE BUILDING PLUMBER HAS COMPLETED THE SERVICE TIE-IN. MARKERS SHALL BE PLACED AT PROPERTY LINE OR ABOVE END OF LINE.

NOTE:
 ALL P.V.C. SANITARY GRAVITY SEWER PIPE SHALL BE:
 FOR DEPTHS BETWEEN 0-4 FEET - DR 18
 FOR DEPTHS 4 FEET OR GREATER - DR 26
 GASKETED FITTINGS SHALL BE THE SAME AS OR GREATER THAN GRADE OF PIPE

DATE: 11/01/2011
DRAWN BY: DEC
APPROVED BY: BRB

TYPICAL RESIDENTIAL SEWER SERVICE WITH RISER

CHARLOTTE COUNTY UTILITIES

PROVIDED FOR INFORMATIONAL PURPOSES ONLY. NO MODIFICATIONS WITHOUT WRITTEN CCU APPROVAL.
GS-09
ID: GS-09-RSR.dwg



ELECTRONIC SERVICE LATERAL MARKER.

ELECTRONIC MARKERS SHALL REMAIN IN POSITION AFTER THE BUILDING PLUMBER HAS COMPLETED THE SERVICE TIE-IN. MARKERS SHALL BE PLACED AT PROPERTY LINE OR ABOVE END OF LINE.

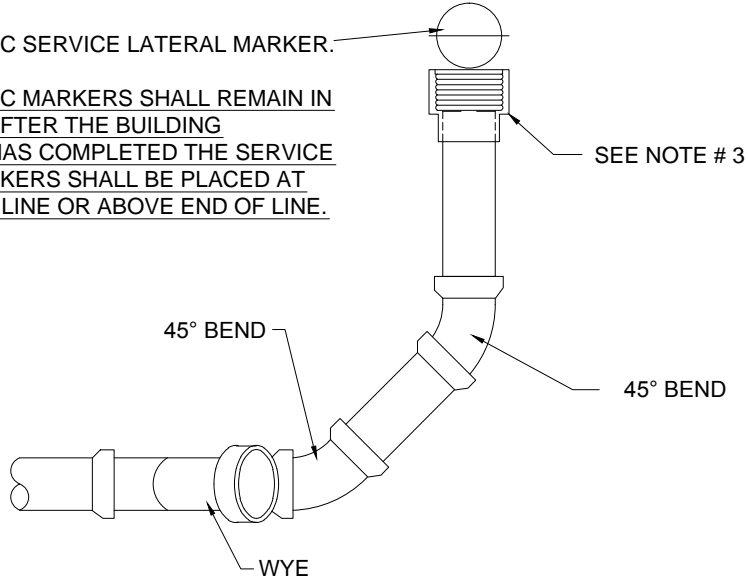

(UNPAVED AREAS)

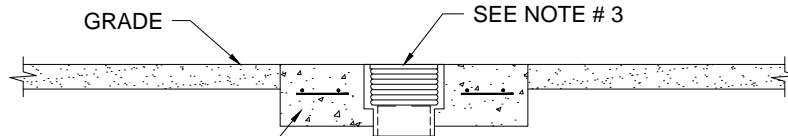

30" SQUARE x 6" THICK CONCRETE SLAB SHALL BE CAST AROUND PVC CAP AND PLACE 2 - #4 REBAR ON ALL SIDES

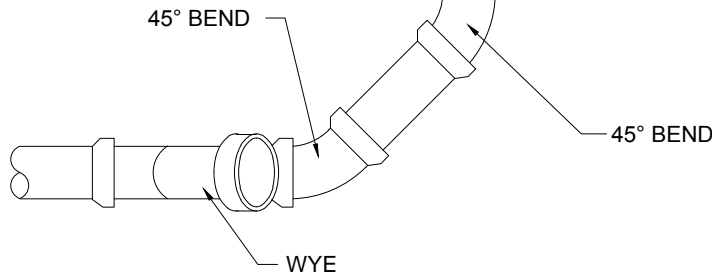

(PAVED AREAS)

NOTES:

1. ALL P.V.C. SANITARY GRAVITY SEWER PIPE SHALL BE:
 - 1.a. FOR DEPTHS BETWEEN 0-4 FEET - DR 18
 - 1.b. FOR DEPTHS 4 FEET BURY DEPTH - DR 26
2. 6" FITTINGS & PIPE FOR SEWER SERVICES.
3. CLEAN-OUT BOX WITH HEXAGONAL COVER MARKED "S"

DATE: 11/01/2011

DRAWN BY: DEC

APPROVED BY: BRB

TYPICAL CLEANOUT DETAIL

CHARLOTTE COUNTY UTILITIES

PROVIDED FOR INFORMATIONAL PURPOSES ONLY. NO MODIFICATIONS WITHOUT WRITTEN CCU APPROVAL.

GS-08

ID: GS-10-SCO.dwg

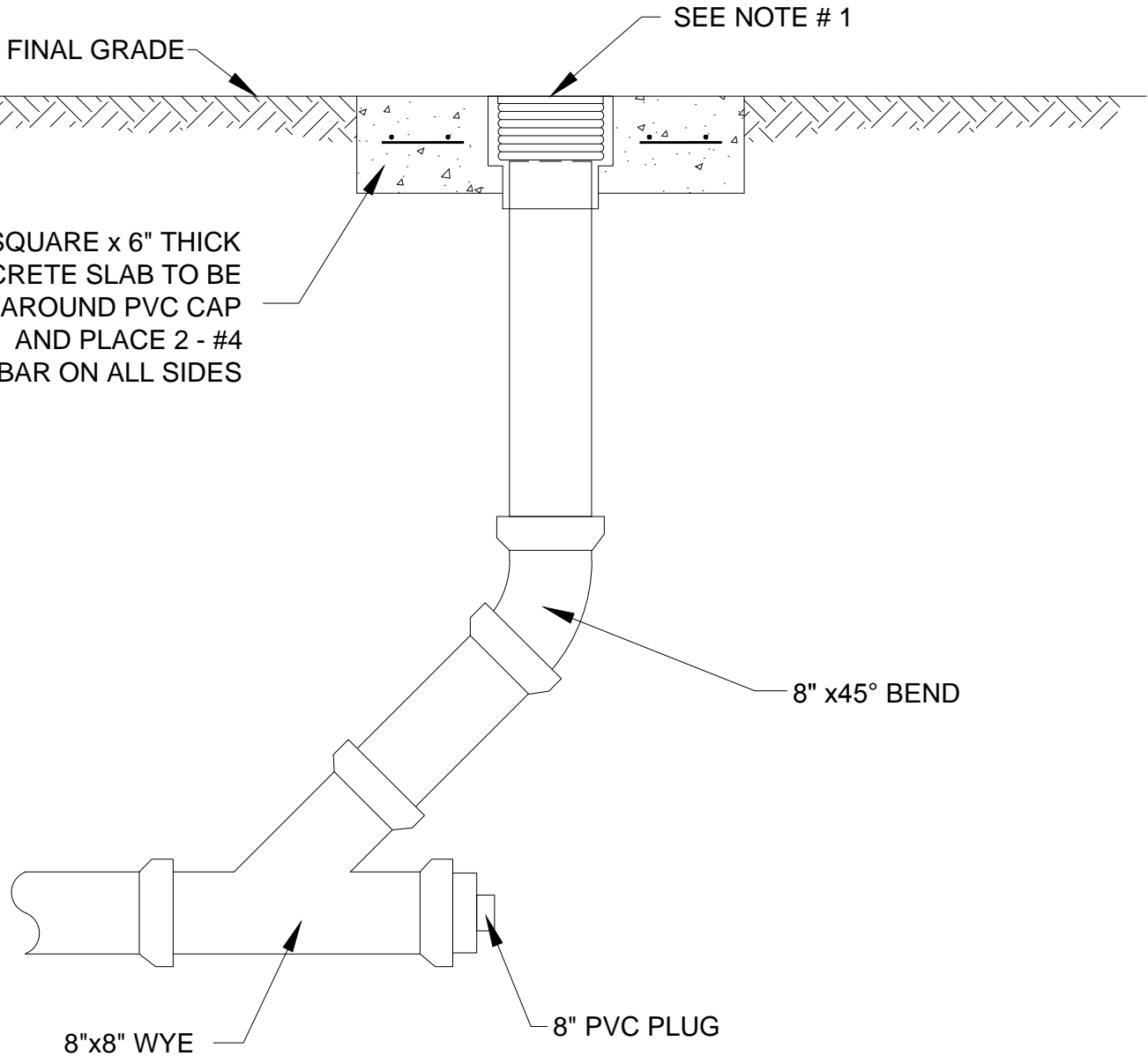

NOTE:

1. CLEAN-OUT BOX WITH HEXAGONAL COVER MARKED "S", WITH THREADED BRASS PLUG IN FEMALE SLIP ON COUPLING.

DATE: 11/01/2011

DRAWN BY: DEC

APPROVED BY: BRB

TEMPORARY TERMINAL CLEANOUT

CHARLOTTE COUNTY UTILITIES

PROVIDED FOR INFORMATIONAL
PURPOSES ONLY.
NO MODIFICATIONS WITHOUT
WRITTEN CCU APPROVAL.

GS-11

ID: GS-11-TCO.dwg

(2) NON-PENETRATING PICKHOLES

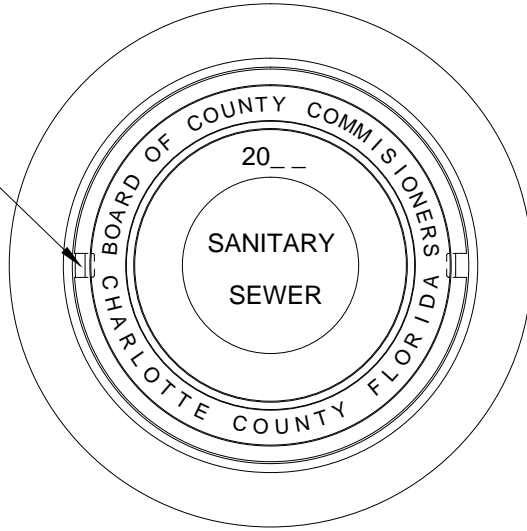

NOTE: MANHOLE COVER SHALL NOT HAVE ALIGNMENT TABS

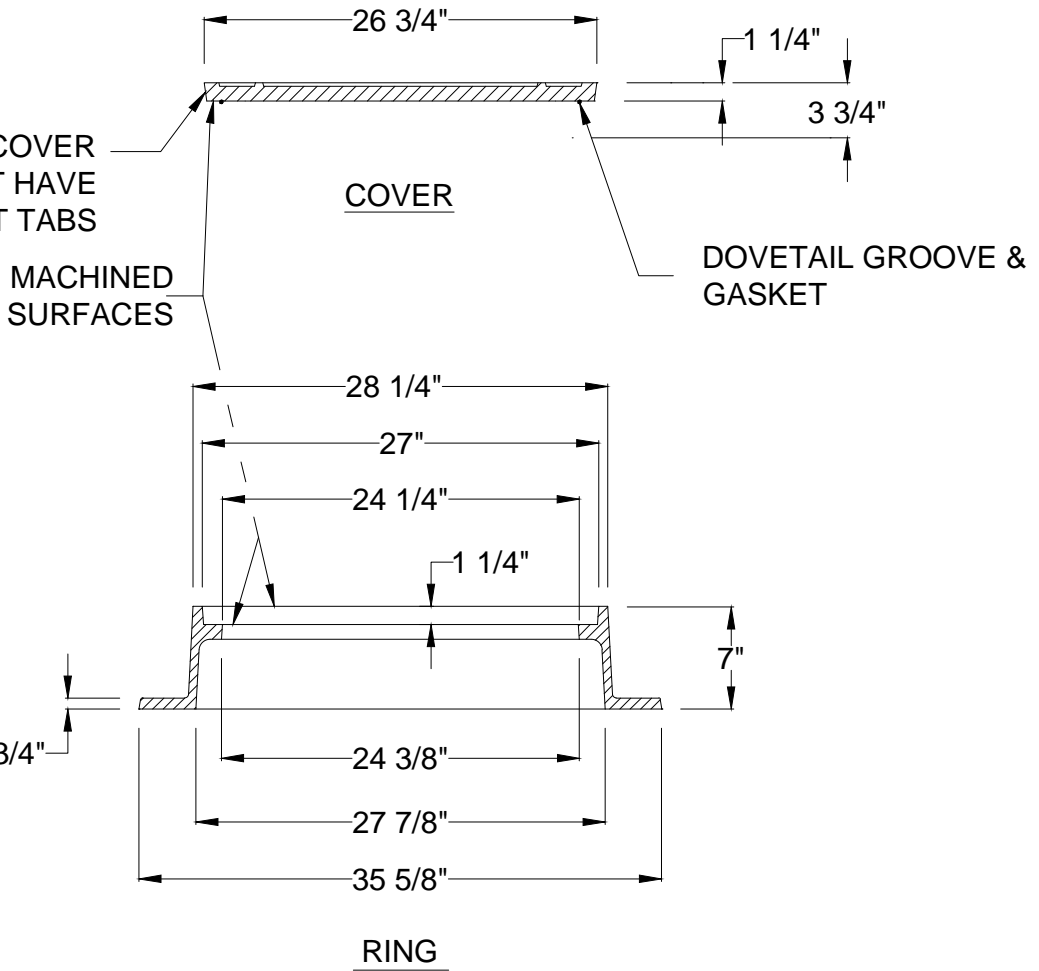

** AVAILABLE IN HINGED MODEL **

DATE: 11/01/2011

DRAWN BY: DEC

APPROVED BY: BRB

MANHOLE RING & COVER

CHARLOTTE COUNTY UTILITIES

PROVIDED FOR INFORMATIONAL PURPOSES ONLY. NO MODIFICATIONS WITHOUT WRITTEN CCU APPROVAL.

GS-12

ID: GS-12-MHRC.dwg

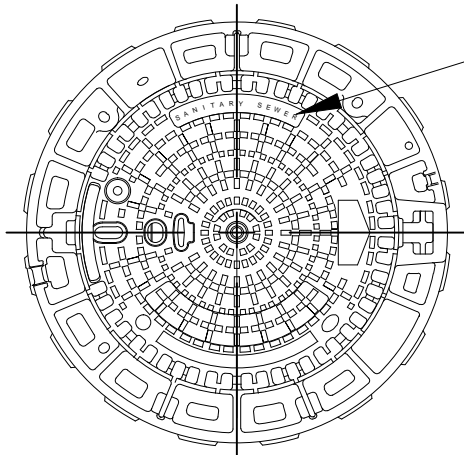

MANHOLE SHALL BE
LABELED SANITARY SEWER

COVER

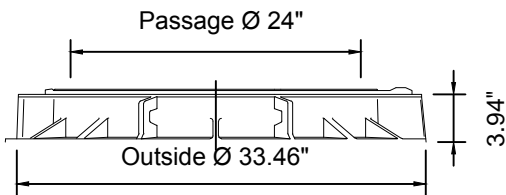
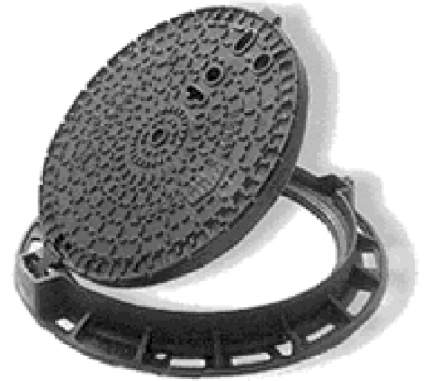

RING

NOTE:

MANHOLE COVER AND FRAME SHALL BE PAMREX OR
EQUAL. MIN. FRAME WEIGHT: 73 LBS. COVER WEIGHT:
122 LBS. TOTAL WEIGHT 195 LBS.

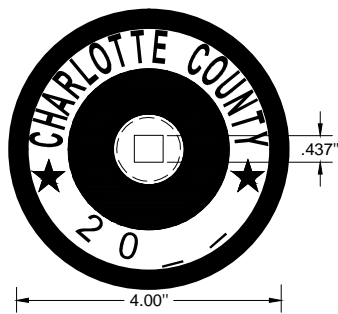
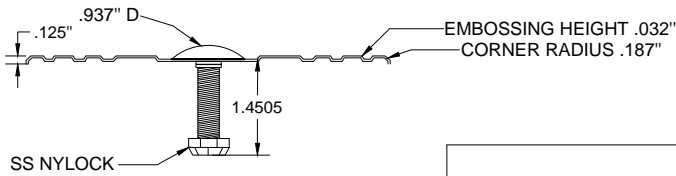

MANHOLE TAG

FINISH		
NATURAL FINISH		
MATERIAL	THICKNESS	WEIGHT
304 ANNEALED STAINLESS STEEL	.062"	.218 LBS.
OPTIONS / ACCESORIES		
SQUARE HOLE:	.437" FOR S.S. CARRAGE BOLT	

Z:\Auto Cad R14\DETAILS\2012 Details\03.GRAVITY SEWER\GS-13-HMHRC.dwg

DATE: 11/01/2011

DRAWN BY: DEC

APPROVED BY: BRB

HINGED MANHOLE RING & COVER

CHARLOTTE COUNTY UTILITIES

PROVIDED FOR INFORMATIONAL
PURPOSES ONLY.
NO MODIFICATIONS WITHOUT
WRITTEN CCU APPROVAL.

GS-13

ID: GS-13-HMHRC.dwg

DATE: 11/01/2011

DRAWN BY: DEC

APPROVED BY: BRB

GREASE INTERCEPTOR TANK W/ SAMPLE POINT DETAIL CHARLOTTE COUNTY UTILITIES

PROVIDED FOR INFORMATIONAL PURPOSES ONLY.
NO MODIFICATIONS WITHOUT WRITTEN CCU APPROVAL.

GS-14

ID: GS-14-GIT.dwg

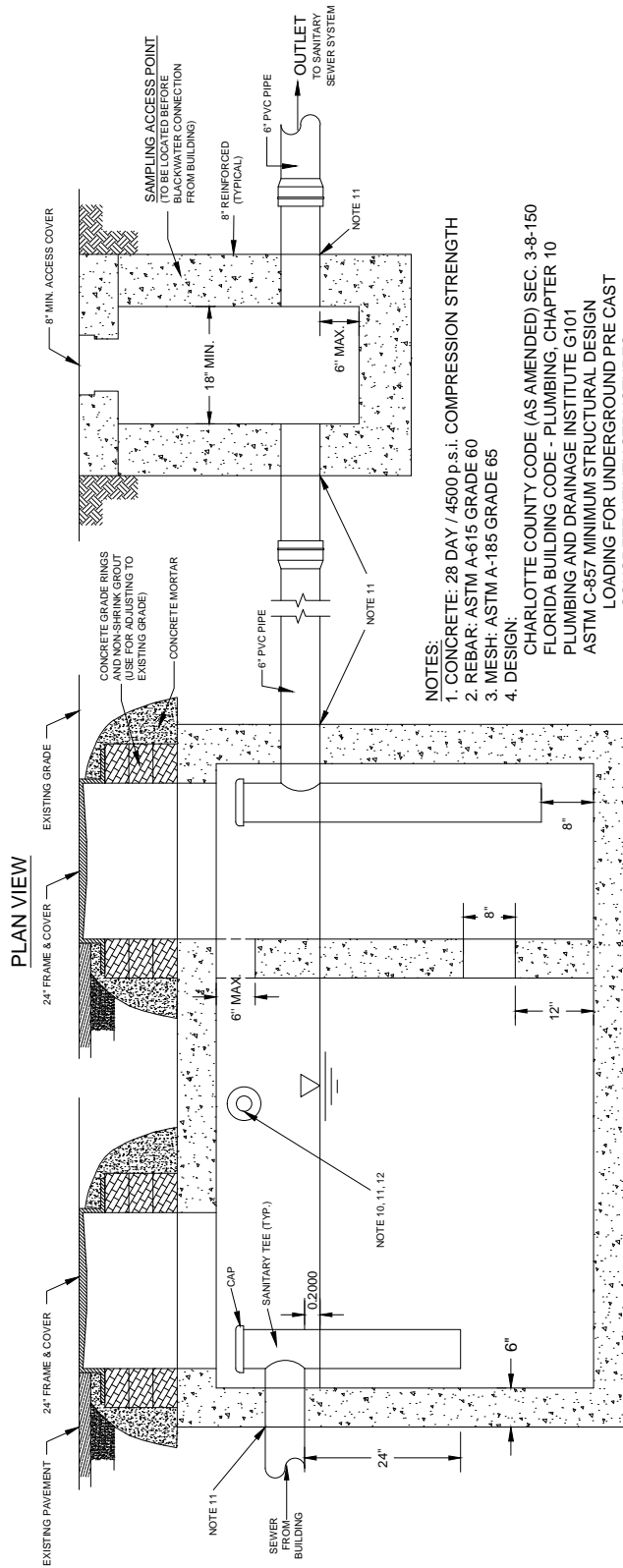
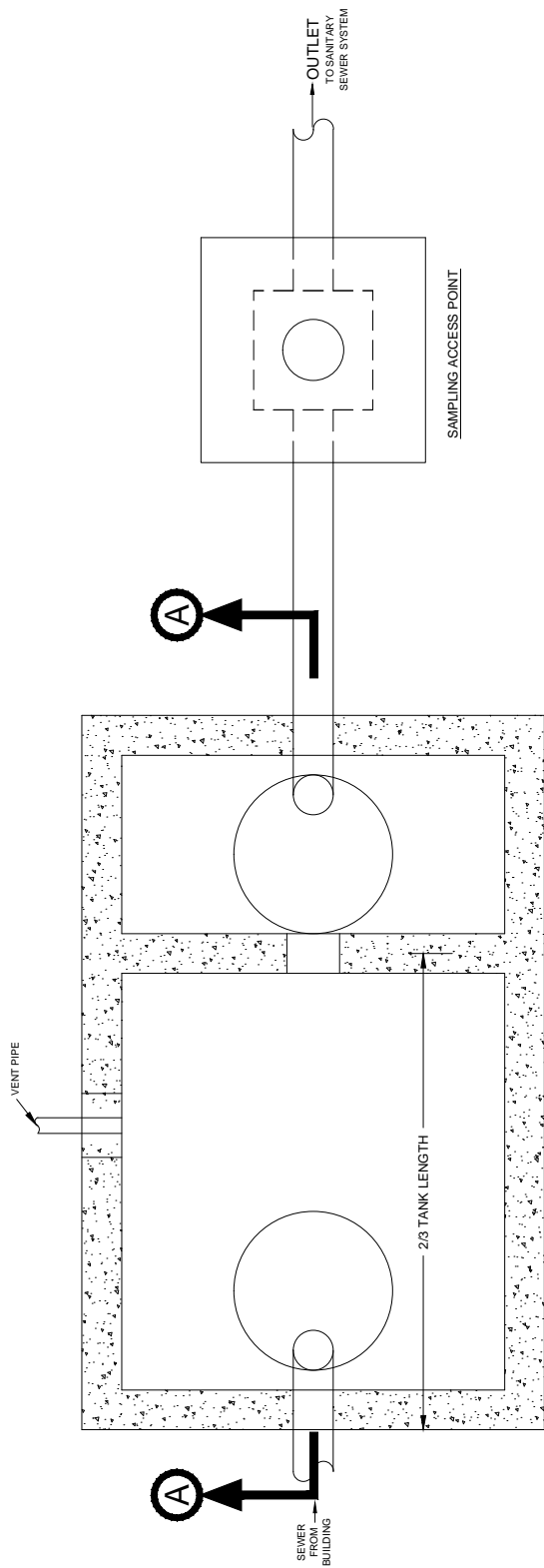

- NOTES:**
1. CONCRETE: 28 DAY / 4500 p.s.i. COMPRESSION STRENGTH
 2. REBAR: ASTM A-615 GRADE 60
 3. MESH: ASTM A-185 GRADE 65
 4. DESIGN: CHARLOTTE COUNTY CODE (AS AMENDED) SEC. 3-8-150
FLORIDA BUILDING CODE - PLUMBING, CHAPTER 10
PLUMBING AND DRAINAGE INSTITUTE G101
ASTM C-867 MINIMUM STRUCTURAL DESIGN
LOADING FOR UNDERGROUND PRE CAST
CONCRETE UTILITY STRUCTURES.
 5. 6" MINIMUM WALL THICKNESS
 6. PREVENT FLOATATION WHEN EMPTY
 7. LOADS: H-20 TRUCK WHEEL W/30% IMPACT PER AASHTO
 8. COMPLETE STRUCTURE AND PIPING TO BE WATERTIGHT
 9. FILL WITH CLEAN WATER PRIOR TO START UP OF SYSTEM
 10. CONTRACTOR TO SUPPLY AND INSTALL ALL PIPING AND SANITARY TEES, CLEAN OUTS FOR CLEANING TOWARD INTERCEPTOR AND FOR CLEANING AWAY FROM INTERCEPTOR ON BOTH THE INLET AND OUTLET / ALT. DUAL SWEEP CLEAN OUTS
 11. GRAY WATER ONLY. BLACK WATER SHALL BE CARRIED BY SEPARATE SEWER TO A POINT DOWNSTREAM OF THE GREASE INTERCEPTOR.
 12. 4" DIAMETER VENT HOLE.
 13. BOOT TO BE SUPPLIED WITH TANK.
 14. SEAL HOLE IF VENT NOT INSTALLED.

RESTAURANT WITH PAPER PLATES

INTERCEPTOR VOLUME (GALLONS) @ X HOURS OF RESTAURANT OPERATIONS PER DAY				
SEATS UP TO	<4 HOURS CLASS 1 & 2	4-8 HOURS CLASS 3 & 4	8-12 HOURS CLASS 5	GREATER THAN 12 HOURS CLASS 6
25	750	750	750	750
50	750	750	750	750
75	750	750	750	1000
100	750	750	1000	1250
125	750	1000	1250	1600
150	750	1000	1600	2000
175	750	1250	2000	2500
200	750	1600	2000	2500
250	1000	2000	2500	3000
>250	SUBMIT DESIGN USING FLORIDA BUILDING CODE - PLUMBING, TABLE 1003.5.1			

EXAMPLE:

125 SEAT RESTAURANT THAT SERVES MEALS IN BASKETS WITH PLASTIC FORKS AND KNIVES (SO SERVICE DISHES WASHED) THAT IS OPEN 8 HOURS A DAY. A MINIMUM SIZE GREASE INTERCEPTOR REQUIRED IS 833 GALLONS CAPACITY. LOCAL AVAILABILITY OF A GREASE INTERCEPTOR MAY REQUIRE THE NEXT LARGEST MANUFACTURED SIZE OF 1,000 GALLONS CAPACITY.

RESTAURANT WITH CHINA PLATES

INTERCEPTOR VOLUME (GALLONS) @ X HOURS OF RESTAURANT OPERATIONS PER DAY				
SEATS UP TO	<4 HOURS CLASS 1 & 2	4-8 HOURS CLASS 3 & 4	8-12 HOURS CLASS 5	GREATER THAN 12 HOURS CLASS 6
25	750	750	750	750
50	750	1000	1250	1600
75	750	1250	2000	2500
100	1000	2000	2500	3000
125	1250	2000	3500	4000
150	1250	2500	4000	4500
175	1600	3000	4500	5100
200	2000	3500	5000	5800
250	2000	4500	6250	7300
>250	SUBMIT DESIGN USING FLORIDA BUILDING CODE - PLUMBING, TABLE 1003.5.1			

EXAMPLE:

100 SEAT RESTAURANT THAT SERVES MEALS ON WASHABLE PLATES (CHINA) THAT IS OPEN 8 HOURS A DAY. THE MINIMUM SIZE GREASE INTERCEPTOR REQUIRED IS 1,667 GALLONS CAPACITY. LOCAL AVAILABILITY OF A GREASE INTERCEPTOR MAY REQUIRE THE NEXT LARGEST MANUFACTURED SIZE OF 2,000 GALLONS CAPACITY.

GREASE INTERCEPTOR VOLUME REQUIREMENT

NOTES:

1. MINIMUM SIZE IS 750 GALLONS
2. INTERCEPTOR TANKS MAY BE PLACED IN SERIES TO ACHIEVE TOTAL VOLUME
3. THE RESTAURANT GREASE INTERCEPTOR SIZE TABLE ABOVE IS BASED ON TABLE 1003.5.1, FLORIDA PLUMBING CODE. REFER TO TABLE 1003.5.1 FOR DESIGN OF GREASE INTERCEPTORS THAT ARE REQUIRED FOR OTHER ESTABLISHMENTS WITH COMMERCIAL KITCHENS
4. GREASE INTERCEPTORS SHALL COMPLY WITH FLORIDA BUILDING CODE, PLUMBING, CHAPTER 10 - TRAPS, INTERCEPTORS AND SEPARATORS.

CLASS 1 = BREAKFAST ONLY, CLOSED BY 11:00AM, OPEN <4 HOURS
 CLASS 2 = LUNCH ONLY, CLOSED BY 3:00 PM, OPEN <4 HOURS
 CLASS 3 = DINNER ONLY, OPEN 4-8 HOURS
 CLASS 4 = BREAKFAST & LUNCH, OPEN 4-8 HOURS
 CLASS 5 = LUNCH & DINNER, OPEN 8-12 HOURS
 CLASS 6 = ALL MEALS, OPEN MORE THAN 12 HOURS

DATE: 11/01/2011

DRAWN BY: DEC

APPROVED BY: BRB

GREASE INTERCEPTOR VOLUME REQUIREMENT CHARLOTTE COUNTY UTILITIES

PROVIDED FOR INFORMATIONAL
PURPOSES ONLY.
NO MODIFICATIONS WITHOUT
WRITTEN CCU APPROVAL.

GS-15

ID: GS-15-GIT-TBL