

MINUTES
BURNT STORE VILLAGE STREET & DRAINAGE
MUNICIPAL SERVICE BENEFIT UNIT (MSBU)

ADVISORY BOARD SPECIAL MEETING
WEDNESDAY, APRIL 27, 2022

10:16 a.m. – 11:38 a.m.
Punta Gorda Charlotte Library
401 Shreve Street, Punta Gorda, Florida

Members Present: Dave Servis, Chair
Harold Sarver, Vice-Chair
Roy McElwee
Craig Williams
Jeffrey Young

Members Absent: None

County Staff: Karlene McDonald, Community Liaison
Chuck Peters, Projects Manger

Guests: None

Call to Order / Roll Call:

The meeting was called to order at 10:16 a.m. A roll call was taken, and a quorum was present.

Citizen Input on Agenda Items (3-Minute Limit):

None

Unfinished Business:

- a. Burnt Store Village Cul-de-Sac Landscaping: Discussion ensued regarding cul-de-sac landscaping; it was unanimously decided to focus efforts on 3 cul-de-sacs. Mr. Sarver motioned to install lava rock for all 3 cul-de-sacs, 15, 16 and 20, seconded by Mr. Young. Deliberation followed regarding reducing the list to 2 cul-de-sacs. Mr. Chair called for a vote on the question and was unanimously approved. Mr. Sarver suggested increasing the budget from \$7,500 to \$10,000 and selecting plant material. Ms. McDonald reminded the Advisory Board that only minor changes can be made to the cul-de-sac landscape designs otherwise a landscape architect will need to draft new plans at an additional cost. Mr. Sarver motioned to amend the budget to \$10,000 for cul-de-sac landscaping, seconded by Mr. Young and unanimously approved. Conversation followed regarding what landscape design option would best fit for the cul-de-sacs. Mr. Peters believes \$10,000 will not be sufficient for 3 cul-de-sacs, with inflation and the development boom, installation, and delivery fees, it may only be enough for one. He also noted that areas without irrigation will not receive a 1-year warranty from a contractor unless the MSBU funds a watering program. Ms. McDonald re-confirmed that County installed landscaping will be maintained by the County. Mr. Peters reiterated that due to the underground utilities and lack of irrigation that Public Works does not recommend landscaping the cul-de-sacs. The Advisory Board agreed to move forward with the project and Mr. Peters stated there are two options to move forward, first the

Advisory Board can request a quote from the current landscape maintenance contractor for installation and maintenance or submit a request for quotes to the Purchasing Department. Mr. Young inquired about the POA installing the landscaping. Mr. Sarver motioned the first choice be Paloma Court, #20, seconded by Mr. Young. It was requested to include the ranking of all 3 cul-de-sacs and Mr. Young motioned to amend the question to read due to budgetary restraints not to exceed \$10,000, the priority will be #20 first, #16 second and #15 third, seconded by Mr. Sarver and the amended motion was unanimously approved. Mr. Young motioned to obtain a quote from the landscape maintenance contractor for installation, seconded by Mr. Sarver and unanimously approved. It was agreed that if lava rock cannot be funded under the \$10,000 budget, mulch will be substituted. Mr. Young Motioned to follow landscape plan, D2, for cul-de-sacs 20 and 16, replacing the ground covering with dwarf holly and variegated arborical, seconded by Mr. Sarver and unanimously approved.

Citizen Input on MSBU Items (3 Minute Limit):

None

Advisory Board Open Discussion:

Conversation followed regarding community entrance signs. Mr. McElwee inquired about any updates on the paving program.

Meeting Schedule / Items for Next Agenda:

Mr. Sarver requested buffer landscape irrigation and Mr. Williams requested the golf cart community request be added to the next agenda. The Advisory Board approved the 2022 meeting schedule; future meetings are scheduled at 10:00 a.m. at the Punta Gorda Charlotte Library:

- June 6, 2022
- September 12, 2022
- December 12, 2022

The meeting adjourned at 11:38 a.m.

Submitted by: Karlene McDonald
Public Works Department

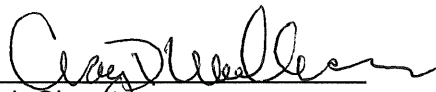
Chair Signature

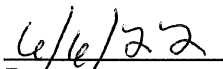
Date

**AGENDA
BURNT STORE VILLAGE STREET & DRAINAGE
MUNICIPAL SERVICE BENEFIT UNIT (MSBU)**

**ADVISORY BOARD SPECIAL MEETING
WEDNESDAY, APRIL 27, 2022**

**10:15 a.m. Punta Gorda Charlotte Library
401 Shreve Street, Punta Gorda, Florida**

BOARD MEMBERS: Craig Williams, Chair
Jeffrey Young, Vice-Chair
Harold Sarver
Dave Servis
Roy McElwee

COUNTY STAFF: Karlene McDonald, Community Liaison

PURPOSE: Regular Meeting

1. Call to Order / Roll Call
2. Citizen Input on Agenda Items (3-Minute Limit)
3. Unfinished Business
 - a. Burnt Store Village Cul-de-Sac Landscaping
4. Citizen Input MSBU Items (3-Minute Limit)
5. Advisory Board Open Discussion
6. Meeting Schedule / Items for Next Agenda
7. Motion to Adjourn

**BURNT STORE VILLAGE
CUL-DE-SAC
LANDSCAPE ENHANCEMENT MANUAL**

PREPARED FOR:

CHARLOTTE COUNTY BOARD OF COUNTY COMMISSIONERS

18500 MURDOCK CIRCLE

PORT CHARLOTTE, FLORIDA 33948

PREPARED BY:

CHARLOTTE ENGINEERING & SURVEYING, INC.

1700 EL JOBEAN ROAD

PORT CHARLOTTE, FLORIDA 33948

CONTENTS

- PROJECT DESCRIPTION
- RECOMMENDED PLANT LIST
- CUL-DE-SAC LOCATION MAP
- CUL-DE-SAC DESCRIPTION AND RECOMMENDATIONS

APPENDIX

- PLANTING PLANS
- PLANTING DETAILS
- PLANTING SPECIFICATIONS

PROJECT DESCRIPTION

The firm of Charlotte Engineering & Surveying, Inc. has been requested to provide Landscape Architecture Services for the Burnt Store Village, Cul-de-sac Landscape Enhancement program. The project consists of evaluating and making recommendations for (30) thirty cul-de-sac's located throughout the subdivision. Burnt Store Village is located in South Charlotte County, with Burnt Store Road to the West and Zemel Road to the North.

This area of Charlotte County exhibits a moderate climate with an occasional frost/freeze during the winter months, which can vary from one year to the next. Soils in the area are generally sandy, poorly drained soils, low in organic matter with a moderate to high ph (alkaline). The area is subject to saltwater intrusion and irrigation water via well or groundwater is not recommended.

Each cul-de-sac has been reviewed individually and recommendations, including planting schemes, are included. A recommended planting list is also included to allow the Owner/Charlotte County to modify the planting schemes as desired.

Water for irrigation is not available and shall be the responsibility of the Contractor. The Contractor shall water all plant materials as specified in the "STANDARD CHARLOTTE COUNTY LANDSCAPE PLANTINGS INSTALLATION & MAINTENANCE SPECIFICATIONS" item No. 29.

All cul-de-sac's shall be evaluated for suitable soils. Inspect existing soils for road base, rocks and compaction. If any is encountered it shall be brought to the attention of Charlotte County. No plantings shall be installed until directed to by Charlotte County.

The Contractor shall remove all grass and weeds from the planting beds, add soil amendments and grade the planting beds to provide positive drainage. Refer to the planting specifications for additional specific soil amendments and other bed preparation requirements, i.e. percolation rates. After the installation of the plant materials and prior to mulching a pre-emergent herbicide should be applied to control weed growth.

RECOMMENDED PLANT LIST

SMALL TREES

Callistemon 'Red Cluster'(Red Cluster Bottlebrush)

Ilex attenuata 'East Palatka'(East Palatka Holly)

Lagerstroemia indica(Crape Myrtle)

Ligustrum japonicum(Tree Form Japanese Privet)

Myrica cerifera(Tree Form Wax Myrtle)

PALMS

Phoenix roebelenii(Pygmy Date Palm)

Phoenix sylvestris(Silver Date Palm)

Roystonea regia(Florida Royal Palm)

Sabal palmetto(Cabbage Palm)

Wodyetia bifurcata(Foxtail Palm)

SHRUBS

Leucophyllum frutescens(Texas Sage)

Loropetalum chinense(Chinese Fringe Bush)

Myrcianthes fragrans(Simpson Stopper)

Myrica cerifera(Wax Myrtle)

Schefflera arboricola 'Variegata'(Var. Dwarf Schefflera)

GROUNDCOVER

Carissa macrocarpa 'Emerald Blanket'(Dwarf Natal Plum)

Catharanthus roseus (Periwinkle)

Dianella tasmanica 'Variegata'(Var. Flax Lily)

Diets bicolor(Yellow African Iris)

Helianthus debilis(Dune Sunflower)

Ilex vomitoria 'Stokes Dwarf'(Dwarf Yaupon Holly)

Ipomoea pes-caprae(Railroad Vine)

Raphiolepis indica(Indian Hawthorn)

Tulbaghia violacea(Society Garlic)

Viburnum obovatum densa(Dwarf Walter's Viburnum)

Zamia pumila(Coontie)

GRASSES

Eragrostis elliottii(Elliott Love Grass)

Muhlenbergia capillaris(Muhly Grass)

Spartina patens(Saltmeadow Cordgrass)

Tripsacum dactyloides(Fakahatchee Grass)



Cul-De-Sac Location Map

NTS

<p>Charlotte Engineering & Surveying, Inc. 1700 El Jobean Road Port Charlotte, Florida 33948 Telephone No (941) 629-2532 Fax No (941) 743-8296</p>	<p>Burnt Store Village/Cul-De-Sac Landscape Enhancement Plans Charlotte County, Florida</p>	<p>Date: 17 April 2013</p>	<p>Sheet:</p>
		<p>Project No. 112690</p>	<p>—</p>

CUL-DE-SAC - 1



DESCRIPTION:

Cul-de-sac number 1 is located on Mintra Court and contains an existing Yucca and Southern Red Cedar. The groundcover vegetation consists of grass/weeds. An existing CCU water service line is located inside the cul-de-sac and its perimeter contains a (6) six inch type 'D' curb.

RECOMMENDATIONS:

- Remove existing Yucca and Southern Red Cedar.
- Remove existing grass/weeds. Re-grade to provide positive drainage.
- Inspect existing soils for road base, rocks and compaction. If any is encountered it shall be brought to the attention of Charlotte County. No plantings shall be installed until directed to by Charlotte County.
- Two (2) inches of Soil amendments shall be incorporated into the top six (6) inches of existing soil. Additional soil amendments shall be added to tree and palm planting pits per the details and specifications.
- Install cul-de-sac "D2" planting plan. See Appendix.
- Water plantings per the water specifications and schedule. Alternative watering methods may be utilized if approved by Charlotte County.
- Broadcast a pre-emergent herbicide "Snap-Shot" or equivalent prior to mulching.
- Provide three (3) inch depth of Melaleuca Mulch.

CUL-DE-SAC – 2



DESCRIPTION:

Cul-de-sac number 2 is located on Esmeralda Court and contains an existing Cabbage Palm located in the center of the island. The groundcover vegetation consists of grass/weeds. An existing CCU water service line is located inside the cul-de-sac and its perimeter contains a (6) six inch type 'D' curb.

RECOMMENDATIONS:

- Remove existing grass/weeds. Re-grade to provide positive drainage.
- Prune the existing Cabbage Palm, removing the lower 1/3rd of the fronds.
- Inspect existing soils for road base, rocks and compaction. If any is encountered it shall be brought to the attention of Charlotte County. No plantings shall be installed until directed to by Charlotte County.
- Two (2) inches of Soil amendments shall be incorporated into the top six (6) inches of existing soil. Additional soil amendments shall be added to tree and palm planting pits per the details and specifications.
- Install cul-de-sac "B" planting plan. See Appendix.
- Water plantings per the water specifications and schedule. Alternative watering methods may be utilized if approved by Charlotte County.
- Broadcast a pre-emergent herbicide "Snap-Shot" or equivalent prior to mulching.
- Provide three (3) inch depth of Melaleuca Mulch.

CUL-DE-SAC - 3



DESCRIPTION:

Cul-de-sac number 3 is located on Navarro Court and contains an existing Cabbage Palm off-set from the center of the island. The groundcover vegetation consists of grass/weeds. An existing CCU water service line is located inside the cul-de-sac and its perimeter contains a (6) six inch type 'D' curb.

RECOMMENDATIONS:

- Remove existing grass/weeds. Re-grade to provide positive drainage.
- Prune the existing Cabbage Palm, removing the lower 1/3rd of the fronds.
- Inspect existing soils for road base, rocks and compaction. If any is encountered it shall be brought to the attention of Charlotte County. No plantings shall be installed until directed to by Charlotte County.
- Two (2) inches of Soil amendments shall be incorporated into the top six (6) inches of existing soil. Additional soil amendments shall be added to tree and palm planting pits per the details and specifications.
- Install cul-de-sac "A" planting plan. See Appendix.
- Water plantings per the water specifications and schedule. Alternative watering methods may be utilized if approved by Charlotte County.
- Broadcast a pre-emergent herbicide "Snap-Shot" or equivalent prior to mulching.
- Provide three (3) inch depth of Melaleuca Mulch.

CUL-DE-SAC - 4



DESCRIPTION:

Cul-de-sac number 4 is located on Delgado Drive and contains an existing Washington Palm offset from the center of the island. Other existing vegetation consists of a bougainvillea, prickly pear cactus and grass/weeds. An existing CCU water service line is located inside the cul-de-sac and its perimeter contains a (6) six inch type 'D' curb.

RECOMMENDATIONS:

- Remove existing grass/weeds. Re-grade to provide positive drainage.
- Prune the existing Washington Palm, removing the lower 1/3rd of the fronds.
- Inspect existing soils for road base, rocks and compaction. If any is encountered it shall be brought to the attention of Charlotte County. No plantings shall be installed until directed to by Charlotte County.
- Two (2) inches of Soil amendments shall be incorporated into the top six (6) inches of existing soil. Additional soil amendments shall be added to tree and palm planting pits per the details and specifications.
- Install cul-de-sac "C" planting plan. See Appendix.
- Water plantings per the water specifications and schedule. Alternative watering methods may be utilized if approved by Charlotte County.
- Broadcast a pre-emergent herbicide "Snap-Shot" or equivalent prior to mulching.
- Provide three (3) inch depth of Melaleuca Mulch.

CUL-DE-SAC - 5



DESCRIPTION:

Cul-de-sac number 5 is located on Campo Saro Court and contains an existing Queen Palm located in the center of the island. The remainder of the island consists of mulch. An existing CCU water service line is located inside the cul-de-sac and its perimeter contains a (6) six inch type 'D' curb.

RECOMMENDATIONS:

- Prune the existing Queen Palm, removing the dead fronds.
- Inspect existing soils for road base, rocks and compaction. If any is encountered it shall be brought to the attention of Charlotte County. No plantings shall be installed until directed to by Charlotte County.
- Two (2) inches of Soil amendments shall be incorporated into the top six (6) inches of existing soil. Additional soil amendments shall be added to tree and palm planting pits per the details and specifications.
- Install cul-de-sac "B" planting plan. See Appendix.
- Water plantings per the water specifications and schedule. Alternative watering methods may be utilized if approved by Charlotte County.
- Broadcast a pre-emergent herbicide "Snap-Shot" or equivalent prior to mulching.
- Provide three (3) inch depth of Melaleuca Mulch.

CUL-DE-SAC - 6



DESCRIPTION:

Cul-de-sac number 6 is located on Durango Court and contains an existing Cabbage Palm off-set from the center of the island. The groundcover vegetation consists of grass/weeds. An existing CCU water service line is located inside the cul-de-sac and its perimeter contains a (6) six inch type 'D' curb.

RECOMMENDATIONS:

- Remove existing grass/weeds. Re-grade to provide positive drainage.
- Prune the existing Cabbage Palm, removing the lower 1/3rd of the fronds.
- Inspect existing soils for road base, rocks and compaction. If any is encountered it shall be brought to the attention of Charlotte County. No plantings shall be installed until directed to by Charlotte County.
- Two (2) inches of Soil amendments shall be incorporated into the top six (6) inches of existing soil. Additional soil amendments shall be added to tree and palm planting pits per the details and specifications.
- Install cul-de-sac "A" planting plan. See Appendix.
- Water plantings per the water specifications and schedule. Alternative watering methods may be utilized if approved by Charlotte County.
- Broadcast a pre-emergent herbicide "Snap-Shot" or equivalent prior to mulching.
- Provide three (3) inch depth of Melaleuca Mulch.

CUL-DE-SAC - 7



DESCRIPTION:

Cul-de-sac number 7 is located on Tonawanda Drive and contains an existing Cabbage Palm off-set from the center of the island. The groundcover vegetation consists of grass/weeds. An existing CCU water service line is located inside the cul-de-sac and its perimeter contains a (6) six inch type 'D' curb.

RECOMMENDATIONS:

- Remove existing grass/weeds. Re-grade to provide positive drainage.
- Prune the existing Cabbage Palm, removing the lower 1/3rd of the fronds.
- Inspect existing soils for road base, rocks and compaction. If any is encountered it shall be brought to the attention of Charlotte County. No plantings shall be installed until directed to by Charlotte County.
- Two (2) inches of Soil amendments shall be incorporated into the top six (6) inches of existing soil. Additional soil amendments shall be added to tree and palm planting pits per the details and specifications.
- Install cul-de-sac "A" planting plan. See Appendix.
- Water plantings per the water specifications and schedule. Alternative watering methods may be utilized if approved by Charlotte County.
- Broadcast a pre-emergent herbicide "Snap-Shot" or equivalent prior to mulching.
- Provide three (3) inch depth of Melaleuca Mulch.

CUL-DE-SAC - 8



DESCRIPTION:

Cul-de-sac number 8 is located on Becasse Drive and contains (2) two small Agave. The groundcover vegetation consists of grass/weeds. An existing CCU water service line is located inside the cul-de-sac and its perimeter contains a (6) six inch type 'D' curb.

RECOMMENDATIONS:

- Remove existing Agave.
- Remove existing grass/weeds. Re-grade to provide positive drainage.
- Inspect existing soils for road base, rocks and compaction. If any is encountered it shall be brought to the attention of Charlotte County. No plantings shall be installed until directed to by Charlotte County.
- Two (2) inches of Soil amendments shall be incorporated into the top six (6) inches of existing soil. Additional soil amendments shall be added to tree and palm planting pits per the details and specifications.
- Install cul-de-sac "D1" planting plan. See Appendix.
- Water plantings per the water specifications and schedule. Alternative watering methods may be utilized if approved by Charlotte County.
- Broadcast a pre-emergent herbicide "Snap-Shot" or equivalent prior to mulching.
- Provide three (3) inch depth of Melaleuca Mulch.

CUL-DE-SAC - 9



DESCRIPTION:

Cul-de-sac number 9 is located on Bandito Court and contains an existing Saw Palmetto. The groundcover vegetation consists of grass/weeds. An existing CCU water service line is located inside the cul-de-sac and its perimeter contains a (6) six inch type 'D' curb.

RECOMMENDATIONS:

- Remove existing Saw Palmetto.
- Remove existing grass/weeds. Re-grade to provide positive drainage.
- Inspect existing soils for road base, rocks and compaction. If any is encountered it shall be brought to the attention of Charlotte County. No plantings shall be installed until directed to by Charlotte County.
- Two (2) inches of Soil amendments shall be incorporated into the top six (6) inches of existing soil. Additional soil amendments shall be added to tree and palm planting pits per the details and specifications.
- Install cul-de-sac "D2" planting plan. See Appendix.
- Water plantings per the water specifications and schedule. Alternative watering methods may be utilized if approved by Charlotte County.
- Broadcast a pre-emergent herbicide "Snap-Shot" or equivalent prior to mulching.
- Provide three (3) inch depth of Melaleuca Mulch.

CUL-DE-SAC - 10



DESCRIPTION:

Cul-de-sac number 10 is located on Averio Court and contains no existing vegetation except for grass/weeds. An existing CCU water service line is located inside the cul-de-sac and its perimeter contains a (6) six inch type 'D' curb.

RECOMMENDATIONS:

- Remove existing grass/weeds. Re-grade to provide positive drainage.
- Inspect existing soils for road base, rocks and compaction. If any is encountered it shall be brought to the attention of Charlotte County. No plantings shall be installed until directed to by Charlotte County.
- Two (2) inches of Soil amendments shall be incorporated into the top six (6) inches of existing soil. Additional soil amendments shall be added to tree and palm planting pits per the details and specifications.
- Install cul-de-sac "D1" planting plan. See Appendix.
- Water plantings per the water specifications and schedule. Alternative watering methods may be utilized if approved by Charlotte County.
- Broadcast a pre-emergent herbicide "Snap-Shot" or equivalent prior to mulching.
- Provide three (3) inch depth of Melaleuca Mulch.

CUL-DE-SAC - 11



DESCRIPTION:

Cul-de-sac number 11 is located on Oresto Court and contains a small existing Senegal Date Palm. The groundcover vegetation consists of grass/weeds. An existing CCU water service line is located inside the cul-de-sac and its perimeter contains a (6) six inch type 'D' curb.

RECOMMENDATIONS:

- Remove existing Senegal Date Palm.
- Remove existing grass/weeds. Re-grade to provide positive drainage.
- Inspect existing soils for road base, rocks and compaction. If any is encountered it shall be brought to the attention of Charlotte County. No plantings shall be installed until directed to by Charlotte County.
- Two (2) inches of Soil amendments shall be incorporated into the top six (6) inches of existing soil. Additional soil amendments shall be added to tree and palm planting pits per the details and specifications.
- Install cul-de-sac "D2" planting plan. See Appendix.
- Water plantings per the water specifications and schedule. Alternative watering methods may be utilized if approved by Charlotte County.
- Broadcast a pre-emergent herbicide "Snap-Shot" or equivalent prior to mulching.
- Provide three (3) inch depth of Melaleuca Mulch.

CUL-DE-SAC - 12



DESCRIPTION:

Cul-de-sac number 12 is located on Oresto Court and contains no existing vegetation except for grass/weeds. An existing CCU water service line is located inside the cul-de-sac and its perimeter contains a (6) six inch type 'D' curb.

RECOMMENDATIONS:

- Remove existing grass/weeds. Re-grade to provide positive drainage.
- Inspect existing soils for road base, rocks and compaction. If any is encountered it shall be brought to the attention of Charlotte County. No plantings shall be installed until directed to by Charlotte County.
- Two (2) inches of Soil amendments shall be incorporated into the top six (6) inches of existing soil. Additional soil amendments shall be added to tree and palm planting pits per the details and specifications.
- Install cul-de-sac "D3" planting plan. See Appendix.
- Water plantings per the water specifications and schedule. Alternative watering methods may be utilized if approved by Charlotte County.
- Broadcast a pre-emergent herbicide "Snap-Shot" or equivalent prior to mulching.
- Provide three (3) inch depth of Melaleuca Mulch.

CUL-DE-SAC - 13



DESCRIPTION:

Cul-de-sac number 13 is located on Perdida Court and contains an existing Areca Palm. The groundcover vegetation consists of grass/weeds. An existing CCU water service line is located inside the cul-de-sac and its perimeter contains a (6) six inch type 'D' curb.

RECOMMENDATIONS:

- Remove existing Areca Palm.
- Remove existing grass/weeds. Re-grade to provide positive drainage.
- Inspect existing soils for road base, rocks and compaction. If any is encountered it shall be brought to the attention of Charlotte County. No plantings shall be installed until directed to by Charlotte County.
- Two (2) inches of Soil amendments shall be incorporated into the top six (6) inches of existing soil. Additional soil amendments shall be added to tree and palm planting pits per the details and specifications.
- Install cul-de-sac "D1" planting plan. See Appendix.
- Water plantings per the water specifications and schedule. Alternative watering methods may be utilized if approved by Charlotte County.
- Broadcast a pre-emergent herbicide "Snap-Shot" or equivalent prior to mulching.
- Provide three (3) inch depth of Melaleuca Mulch.

CUL-DE-SAC - 14



DESCRIPTION:

Cul-de-sac number 14 is located on Blanco Drive and contains no existing vegetation except for grass/weeds. An existing CCU water service line is located inside the cul-de-sac and its perimeter contains a (6) six inch type 'D' curb.

RECOMMENDATIONS:

- Remove existing grass/weeds. Re-grade to provide positive drainage.
- Inspect existing soils for road base, rocks and compaction. If any is encountered it shall be brought to the attention of Charlotte County. No plantings shall be installed until directed to by Charlotte County.
- Two (2) inches of Soil amendments shall be incorporated into the top six (6) inches of existing soil. Additional soil amendments shall be added to tree and palm planting pits per the details and specifications.
- Install cul-de-sac "D2" planting plan. See Appendix.
- Water plantings per the water specifications and schedule. Alternative watering methods may be utilized if approved by Charlotte County.
- Broadcast a pre-emergent herbicide "Snap-Shot" or equivalent prior to mulching.
- Provide three (3) inch depth of Melaleuca Mulch.

CUL-DE-SAC - 15



DESCRIPTION:

Cul-de-sac number 15 is located on Laroche Drive and contains an existing Queen Palm and Crape Myrtle. The groundcover vegetation consists of grass/weeds. An existing CCU water service line is located inside the cul-de-sac and its perimeter contains a (6) six inch type 'D' curb.

RECOMMENDATIONS:

- Remove existing Queen Palm and Crape Myrtle.
- Remove existing grass/weeds. Re-grade to provide positive drainage.
- Inspect existing soils for road base, rocks and compaction. If any is encountered it shall be brought to the attention of Charlotte County. No plantings shall be installed until directed to by Charlotte County.
- Two (2) inches of Soil amendments shall be incorporated into the top six (6) inches of existing soil. Additional soil amendments shall be added to tree and palm planting pits per the details and specifications.
- Install cul-de-sac "D1" planting plan. See Appendix.
- Water plantings per the water specifications and schedule. Alternative watering methods may be utilized if approved by Charlotte County.
- Broadcast a pre-emergent herbicide "Snap-Shot" or equivalent prior to mulching.
- Provide three (3) inch depth of Melaleuca Mulch.

CUL-DE-SAC - 16



DESCRIPTION:

Cul-de-sac number 16 is located on Lychee Court and contains no existing vegetation except for grass/weeds. An existing CCU water service line is located inside the cul-de-sac and its perimeter contains a (6) six inch type 'D' curb.

RECOMMENDATIONS:

- Remove existing grass/weeds. Re-grade to provide positive drainage.
- Inspect existing soils for road base, rocks and compaction. If any is encountered it shall be brought to the attention of Charlotte County. No plantings shall be installed until directed to by Charlotte County.
- Two (2) inches of Soil amendments shall be incorporated into the top six (6) inches of existing soil. Additional soil amendments shall be added to tree and palm planting pits per the details and specifications.
- Install cul-de-sac "D1" planting plan. See Appendix.
- Water plantings per the water specifications and schedule. Alternative watering methods may be utilized if approved by Charlotte County.
- Broadcast a pre-emergent herbicide "Snap-Shot" or equivalent prior to mulching.
- Provide three (3) inch depth of Melaleuca Mulch.

CUL-DE-SAC - 17



DESCRIPTION:

Cul-de-sac number 17 is located on Jubal Street and contains an (2) two existing Brazilian Pepper. The groundcover vegetation consists of grass/weeds. An existing CCU water service line is located inside the cul-de-sac and its perimeter contains a (6) six inch type 'D' curb.

RECOMMENDATIONS:

- Remove existing Brazilian Pepper.
- Remove existing grass/weeds. Re-grade to provide positive drainage.
- Inspect existing soils for road base, rocks and compaction. If any is encountered it shall be brought to the attention of Charlotte County. No plantings shall be installed until directed to by Charlotte County.
- Two (2) inches of Soil amendments shall be incorporated into the top six (6) inches of existing soil. Additional soil amendments shall be added to tree and palm planting pits per the details and specifications.
- Install cul-de-sac "D3" planting plan. See Appendix.
- Water plantings per the water specifications and schedule. Alternative watering methods may be utilized if approved by Charlotte County.
- Broadcast a pre-emergent herbicide "Snap-Shot" or equivalent prior to mulching.
- Provide three (3) inch depth of Melaleuca Mulch.

CUL-DE-SAC - 18



DESCRIPTION:

Cul-de-sac number 18 is located on Islas Drive and contains an existing Cabbage Palm off-set from the center of the island. The groundcover vegetation consists of grass/weeds. An existing CCU water service line is located inside the cul-de-sac and its perimeter contains a (6) six inch type 'D' curb.

RECOMMENDATIONS:

- Remove existing grass/weeds. Re-grade to provide positive drainage.
- Prune the existing Cabbage Palm, removing the lower 1/3rd of the fronds.
- Inspect existing soils for road base, rocks and compaction. If any is encountered it shall be brought to the attention of Charlotte County. No plantings shall be installed until directed to by Charlotte County.
- Two (2) inches of Soil amendments shall be incorporated into the top six (6) inches of existing soil. Additional soil amendments shall be added to tree and palm planting pits per the details and specifications.
- Install cul-de-sac "A" planting plan. See Appendix.
- Water plantings per the water specifications and schedule. Alternative watering methods may be utilized if approved by Charlotte County.
- Broadcast a pre-emergent herbicide "Snap-Shot" or equivalent prior to mulching.
- Provide three (3) inch depth of Melaleuca Mulch.

CUL-DE-SAC - 19



DESCRIPTION:

Cul-de-sac number 19 is located on Islas Drive and contains an existing Cabbage Palm off-set from the center of the island. The groundcover vegetation consists of grass/weeds. An existing CCU water service line is located inside the cul-de-sac and its perimeter contains a (6) six inch type 'D' curb.

RECOMMENDATIONS:

- Remove existing grass/weeds. Re-grade to provide positive drainage.
- Prune the existing Cabbage Palm, removing the lower 1/3rd of the fronds.
- Inspect existing soils for road base, rocks and compaction. If any is encountered it shall be brought to the attention of Charlotte County. No plantings shall be installed until directed to by Charlotte County.
- Two (2) inches of Soil amendments shall be incorporated into the top six (6) inches of existing soil. Additional soil amendments shall be added to tree and palm planting pits per the details and specifications.
- Install cul-de-sac "A" planting plan. See Appendix.
- Water plantings per the water specifications and schedule. Alternative watering methods may be utilized if approved by Charlotte County.
- Broadcast a pre-emergent herbicide "Snap-Shot" or equivalent prior to mulching.
- Provide three (3) inch depth of Melaleuca Mulch.

CUL-DE-SAC - 20



DESCRIPTION:

Cul-de-sac number 20 is located on Paloma Court and contains no existing vegetation except for grass/weeds. An existing CCU water service line is located inside the cul-de-sac and its perimeter contains a (6) six inch type 'D' curb.

RECOMMENDATIONS:

- Remove existing grass/weeds. Re-grade to provide positive drainage.
- Inspect existing soils for road base, rocks and compaction. If any is encountered it shall be brought to the attention of Charlotte County. No plantings shall be installed until directed to by Charlotte County.
- Two (2) inches of Soil amendments shall be incorporated into the top six (6) inches of existing soil. Additional soil amendments shall be added to tree and palm planting pits per the details and specifications.
- Install cul-de-sac "D2" planting plan. See Appendix.
- Water plantings per the water specifications and schedule. Alternative watering methods may be utilized if approved by Charlotte County.
- Broadcast a pre-emergent herbicide "Snap-Shot" or equivalent prior to mulching.
- Provide three (3) inch depth of Melaleuca Mulch.

CUL-DE-SAC - 21



DESCRIPTION:

Cul-de-sac number 21 is located on Puerta Drive and contains an existing Oak Tree and Ixora. The remainder of the island contains mulch. An existing CCU water service line is located inside the cul-de-sac and its perimeter contains a (6) six inch type 'D' curb

RECOMMENDATIONS:

- Add (8) eight to (10) ten Schefflera arboricola 'Variegata'(Var. Dwarf Schefflera), 18-24"H & Spr., 3 gal., to the existing plantings.
- Water plantings per the water specifications and schedule. Alternative watering methods may be utilized if approved by Charlotte County.
- Broadcast a pre-emergent herbicide "Snap-Shot" or equivalent prior to mulching.
- Provide three (3) inch depth of Melaleuca Mulch.

CUL-DE-SAC - 22



DESCRIPTION:

Cul-de-sac number 22 is located on Cadiz Drive and contains an Oleander. The remainder of the island consists of mulch and weeds. An existing CCU water service line is located inside the cul-de-sac and its perimeter contains a (6) six inch type 'D' curb.

RECOMMENDATIONS:

- Remove existing Oleander.
- Remove existing mulch and weeds. Re-grade to provide positive drainage.
- Inspect existing soils for road base, rocks and compaction. If any is encountered it shall be brought to the attention of Charlotte County. No plantings shall be installed until directed to by Charlotte County.
- Two (2) inches of Soil amendments shall be incorporated into the top six (6) inches of existing soil. Additional soil amendments shall be added to tree and palm planting pits per the details and specifications.
- Install cul-de-sac "D1" planting plan. See Appendix.
- Water plantings per the water specifications and schedule. Alternative watering methods may be utilized if approved by Charlotte County.
- Broadcast a pre-emergent herbicide "Snap-Shot" or equivalent prior to mulching.
- Provide three (3) inch depth of Melaleuca Mulch.

CUL-DE-SAC - 23



DESCRIPTION:

Cul-de-sac number 23 is located on Cadiz Drive and contains an existing Cabbage Palm off-set from the center of the island with a raised wood timber planter. The groundcover vegetation consists of grass/weeds. An existing CCU water service line is located inside the cul-de-sac and its perimeter contains a (6) six inch type 'D' curb.

RECOMMENDATIONS:

- Remove existing miscellaneous vegetation and grass/weeds.
- Remove raised wood timber planter. Re-grade to provide positive drainage.
- Prune the existing Cabbage Palm, removing the lower 1/3rd of the fronds.
- Inspect existing soils for road base, rocks and compaction. If any is encountered it shall be brought to the attention of Charlotte County. No plantings shall be installed until directed to by Charlotte County.
- Two (2) inches of Soil amendments shall be incorporated into the top six (6) inches of existing soil. Additional soil amendments shall be added to tree and palm planting pits per the details and specifications.
- Install cul-de-sac "A" planting plan. See Appendix.
- Water plantings per the water specifications and schedule. Alternative watering methods may be utilized if approved by Charlotte County.
- Broadcast a pre-emergent herbicide "Snap-Shot" or equivalent prior to mulching.
- Provide three (3) inch depth of Melaleuca Mulch.

CUL-DE-SAC - 24



DESCRIPTION:

Cul-de-sac number 24 is located on Ortega Drive and contains no existing vegetation except for grass/weeds. An existing CCU water service line is located inside the cul-de-sac and its perimeter contains a (6) six inch type 'D' curb.

RECOMMENDATIONS:

- Remove existing grass/weeds. Re-grade to provide positive drainage.
- Inspect existing soils for road base, rocks and compaction. If any is encountered it shall be brought to the attention of Charlotte County. No plantings shall be installed until directed to by Charlotte County.
- Two (2) inches of Soil amendments shall be incorporated into the top six (6) inches of existing soil. Additional soil amendments shall be added to tree and palm planting pits per the details and specifications.
- Install cul-de-sac "D1" planting plan. See Appendix.
- Water plantings per the water specifications and schedule. Alternative watering methods may be utilized if approved by Charlotte County.
- Broadcast a pre-emergent herbicide "Snap-Shot" or equivalent prior to mulching.
- Provide three (3) inch depth of Melaleuca Mulch.

CUL-DE-SAC - 25



DESCRIPTION:

Cul-de-sac number 25 is located on Overdale Court and contains (3) three existing Queen Palms and Oleander. The remainder of the island consists of stone/river rock mulch with weed cloth. An existing CCU water service line is located inside the cul-de-sac and its perimeter contains a (6) six inch type 'D' curb.

RECOMMENDATIONS:

- Remove existing Queen Palms and Oleander.
- Remove existing stone/river rock mulch and weed cloth. Re-grade to provide positive drainage.
- Inspect existing soils for road base, rocks and compaction. If any is encountered it shall be brought to the attention of Charlotte County. No plantings shall be installed until directed to by Charlotte County.
- Two (2) inches of Soil amendments shall be incorporated into the top six (6) inches of existing soil. Additional soil amendments shall be added to tree and palm planting pits per the details and specifications.
- Install cul-de-sac "D2" planting plan. See Appendix.
- Water plantings per the water specifications and schedule. Alternative watering methods may be utilized if approved by Charlotte County.
- Broadcast a pre-emergent herbicide "Snap-Shot" or equivalent prior to mulching.
- Provide three (3) inch depth of Melaleuca Mulch.

CUL-DE-SAC - 26



DESCRIPTION:

Cul-de-sac number 26 is located on Caruna Court and contains an existing Queen Palm located in the center of the island. The remainder of the island consists of mulch. An existing CCU water service line is located inside the cul-de-sac and its perimeter contains a (6) six inch type 'D' curb.

RECOMMENDATIONS:

- Remove existing grass/weeds. Re-grade to provide positive drainage.
- Prune the existing Queen Palm, removing the dead fronds.
- Inspect existing soils for road base, rocks and compaction. If any is encountered it shall be brought to the attention of Charlotte County. No plantings shall be installed until directed to by Charlotte County.
- Two (2) inches of Soil amendments shall be incorporated into the top six (6) inches of existing soil. Additional soil amendments shall be added to tree and palm planting pits per the details and specifications.
- Install cul-de-sac "B" planting plan. See Appendix.
- Water plantings per the water specifications and schedule. Alternative watering methods may be utilized if approved by Charlotte County.
- Broadcast a pre-emergent herbicide "Snap-Shot" or equivalent prior to mulching.
- Provide three (3) inch depth of Melaleuca Mulch.

CUL-DE-SAC - 27



DESCRIPTION:

Cul-de-sac number 27 is located on Quinta Drive and contains no existing vegetation except for grass/weeds. An existing CCU water service line is located inside the cul-de-sac and its perimeter contains a (6) six inch type 'D' curb.

RECOMMENDATIONS:

- Remove existing grass/weeds. Re-grade to provide positive drainage.
- Inspect existing soils for road base, rocks and compaction. If any is encountered it shall be brought to the attention of Charlotte County. No plantings shall be installed until directed to by Charlotte County.
- Two (2) inches of Soil amendments shall be incorporated into the top six (6) inches of existing soil. Additional soil amendments shall be added to tree and palm planting pits per the details and specifications.
- Install cul-de-sac "D1" planting plan. See Appendix.
- Water plantings per the water specifications and schedule. Alternative watering methods may be utilized if approved by Charlotte County.
- Broadcast a pre-emergent herbicide "Snap-Shot" or equivalent prior to mulching.
- Provide three (3) inch depth of Melaleuca Mulch.

CUL-DE-SAC - 28



DESCRIPTION:

Cul-de-sac number 28 is located on Quiche Court and contains no existing vegetation except for grass/weeds. An existing CCU water service line is located inside the cul-de-sac and its perimeter contains a (6) six inch type 'D' curb.

RECOMMENDATIONS:

- Remove existing grass/weeds. Re-grade to provide positive drainage.
- Inspect existing soils for road base, rocks and compaction. If any is encountered it shall be brought to the attention of Charlotte County. No plantings shall be installed until directed to by Charlotte County.
- Two (2) inches of Soil amendments shall be incorporated into the top six (6) inches of existing soil. Additional soil amendments shall be added to tree and palm planting pits per the details and specifications.
- Install cul-de-sac "D2" planting plan. See Appendix.
- Water plantings per the water specifications and schedule. Alternative watering methods may be utilized if approved by Charlotte County.
- Broadcast a pre-emergent herbicide "Snap-Shot" or equivalent prior to mulching.
- Provide three (3) inch depth of Melaleuca Mulch.

CUL-DE-SAC - 29



DESCRIPTION:

Cul-de-sac number 29 is located on Galiano Court and contains (3) three existing Queen Palms and small unknown tree. The remainder of the island consists of grass/weeds. An existing CCU water service line is located inside the cul-de-sac and its perimeter contains a (6) six inch type 'D' curb.

RECOMMENDATIONS:

- Remove existing Queen Palms and unknown vegetation.
- Remove existing grass/weeds. Re-grade to provide positive drainage.
- Inspect existing soils for road base, rocks and compaction. If any is encountered it shall be brought to the attention of Charlotte County. No plantings shall be installed until directed to by Charlotte County.
- Two (2) inches of Soil amendments shall be incorporated into the top six (6) inches of existing soil. Additional soil amendments shall be added to tree and palm planting pits per the details and specifications.
- Install cul-de-sac "D3" planting plan. See Appendix.
- Water plantings per the water specifications and schedule. Alternative watering methods may be utilized if approved by Charlotte County.
- Broadcast a pre-emergent herbicide "Snap-Shot" or equivalent prior to mulching.
- Provide three (3) inch depth of Melaleuca Mulch.

CUL-DE-SAC - 30



DESCRIPTION:

Cul-de-sac number 30 is located on Hesta Misty Court and contains an existing Cabbage Palm off-set from the center of the island and a Pine Tree. The groundcover vegetation consists of grass/weeds. An existing CCU water service line is located inside the cul-de-sac and its perimeter contains a (6) six inch type 'D' curb.

RECOMMENDATIONS:

- Remove existing Pine Tree.
- Remove existing grass/weeds. Re-grade to provide positive drainage.
- Prune the existing Cabbage Palm, removing the lower 1/3rd of the fronds.
- Inspect existing soils for road base, rocks and compaction. If any is encountered it shall be brought to the attention of Charlotte County. No plantings shall be installed until directed to by Charlotte County.
- Two (2) inches of Soil amendments shall be incorporated into the top six (6) inches of existing soil. Additional soil amendments shall be added to tree and palm planting pits per the details and specifications.
- Install cul-de-sac "A" planting plan. See Appendix.
- Water plantings per the water specifications and schedule. Alternative watering methods may be utilized if approved by Charlotte County.
- Broadcast a pre-emergent herbicide "Snap-Shot" or equivalent prior to mulching.
- Provide three (3) inch depth of Melaleuca Mulch.

APPENDIX

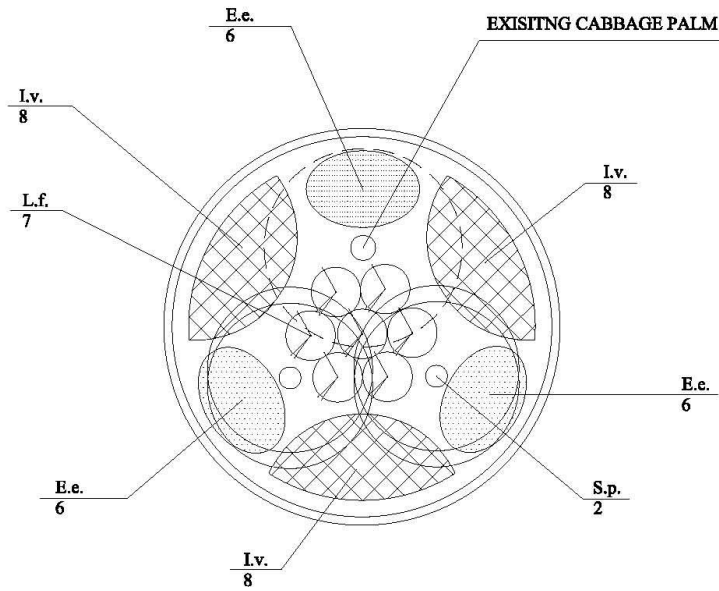

PLANT LIST				
SYMBOL	BOTANICAL(COMMON NAME)	DESCRIPTION	QUANTITY	COMMENTS
PALMS				
S.p.	Sabal palmetto(Cabbage Palm)	10-14"C.T., Remove Fronds and Boots	2	N / FF
SERUBS				
L.f.	Leucophyllum frutescens(Texas Sage)	18-24"H x 12-18"Spr., 3 gal., 36"OC, Full	7	FF
GROUNDCOVERS				
I.v.	Ilex vomitoria 'Stokes Dwarf'(Dwarf Yaupon Holly)	8-12"H & Spr., 3 gal., 30"OC, Full	24	N / FF
E.e.	Eragrostis eliotii(Elliott Love Grass)	8-12"H & Spr., 1 gal., 24"OC, Full	18	N / FF
MISCELLANEOUS				
	Metalaeca Mulch	3" Depth Min.	415 SF	
	Staking and Guying	Per Details	2 Palms	

PLANT LIST LEGEND
N - Native
FF - Florida Friendly

Cul-De-Sac - A

Charlotte Engineering & Surveying, Inc. 1700 El Jobean Road Port Charlotte, Florida 33948 Telephone No: (941) 629-2552 Fax No: (941) 743-8298	Burnt Store Village/Cul-De-Sac Landscape Enhancement Plans Charlotte County, Florida	Date: September 2013	Sheet:
		Project No. 112690	
		SCALE: 1"=10'	—

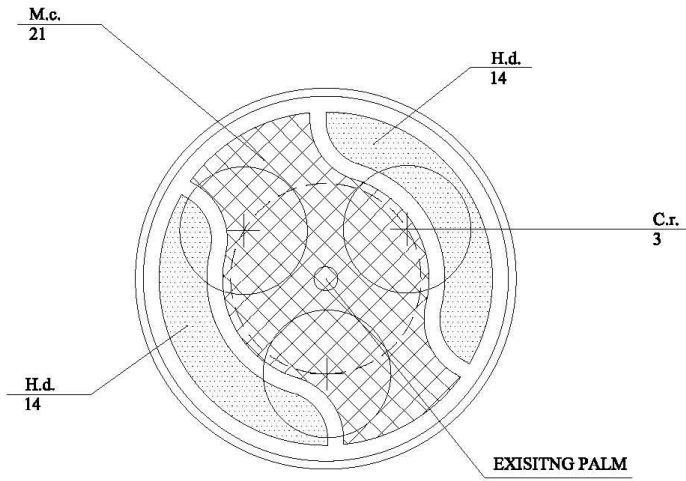

PLANT LIST				
SYMBOL	BOTANICAL(COMMON NAME)	DESCRIPTION	QUANTITY	COMMENTS
SMALL TREES				
C.r.	Callistemon 'Red Cluster'(Red Cluster Bottlebrush)	6-8'H x 4-5'Spr., 25 gal. Full	3	FF
GROUNDCOVERS				
H.d.	Heliopsis scaberrima(Dane Sunflower)	12-18"Spr., 1 gal., 24"OC, Full	28	N / FF
M.c.	Muhlenbergia capillaris(Muhly Grass)	24-30"H & Spr., 3 gal., 36"OC, Full	21	N / FF
MISCELLANEOUS				
	Metasecoia Mulch	3" Depth Min.	415 SF	
	Staking and Guying	Per Details	3 Trees	

PLANT LIST LEGEND
N - Native
FF - Florida Friendly

Cul-De-Sac - B

Charlotte Engineering & Surveying, Inc. 1700 El Jobean Road Port Charlotte, Florida 33948 Telephone No: (941) 629-2552 Fax No: (941) 743-6296	Burnt Store Village/Cul-De-Sac Landscape Enhancement Plans Charlotte County, Florida	Date: September 2013	Sheet:
		Project No. 112690	
		SCALE: 1"=10'	—

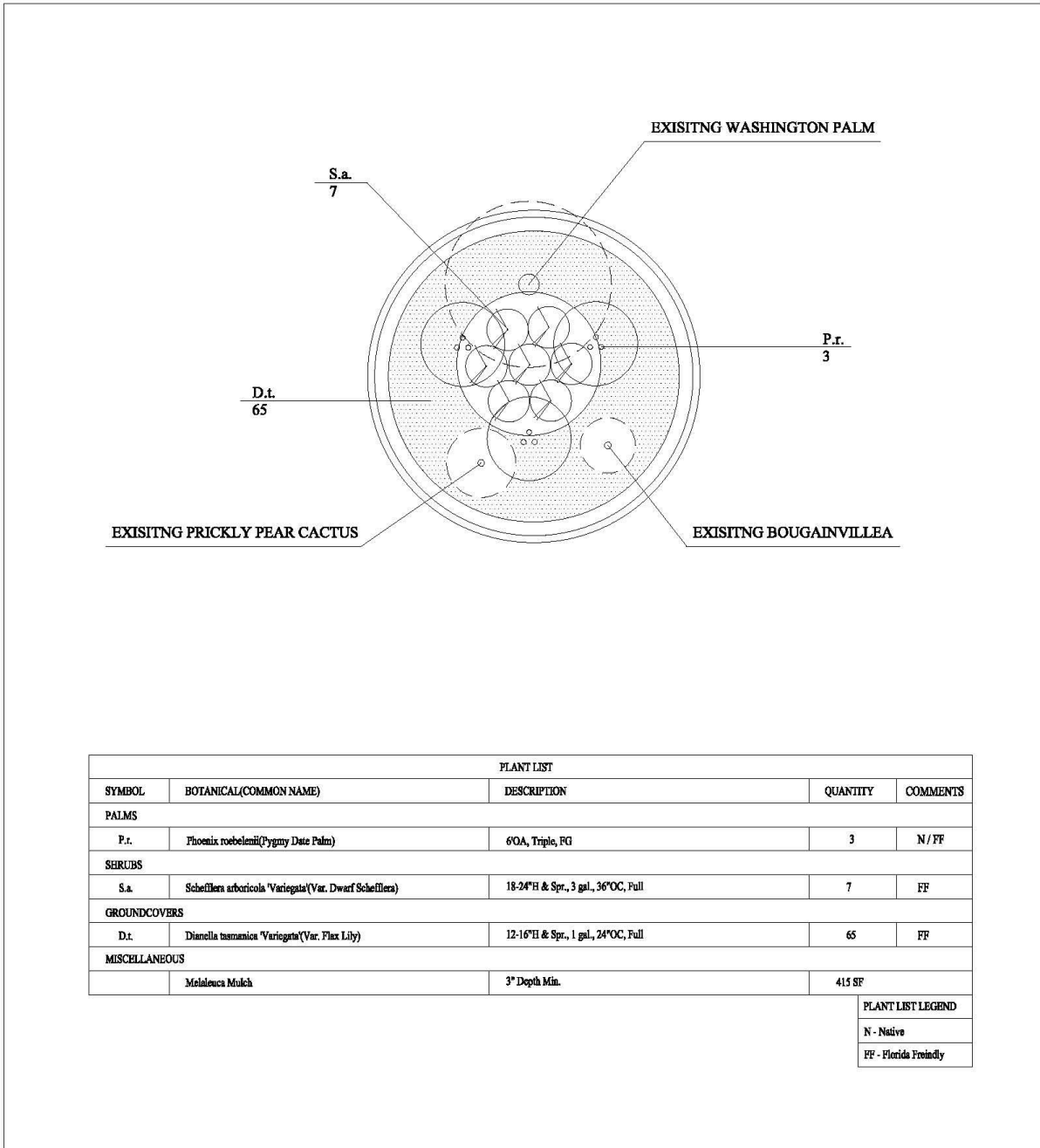

PLANT LIST				
SYMBOL	BOTANICAL(COMMON NAME)	DESCRIPTION	QUANTITY	COMMENTS
PALMS				
P.r.	Phoenix roebelenii(Pygmy Date Palm)	6'OA, Triple, FG	3	N / FF
SHRUBS				
S.a.	Scheffera arboricola 'Variegata'(Var. Dwarf Schefflera)	18-24"H & Spr., 3 gal., 36"OC, Full	7	FF
GROUNDCOVERS				
D.t.	Dianella tasmanica 'Variegata'(Var. Flax Lily)	12-16"H & Spr., 1 gal., 24"OC, Full	65	FF
MISCELLANEOUS				
	Melaleuca Mulch	3" Depth Min.	415 SF	

PLANT LIST LEGEND
N - Native
FF - Florida Friendly

Cul-De-Sac - C

Charlotte Engineering & Surveying, Inc. 1700 El Jobean Road Port Charlotte, Florida 33948 Telephone No: (941) 629-2552 Fax No: (941) 743-6296	Burnt Store Village/Cul-De-Sac Landscape Enhancement Plans Charlotte County, Florida	Date: September 2013	Sheet:
		Project No. 112690	
		SCALE: 1"=10'	—

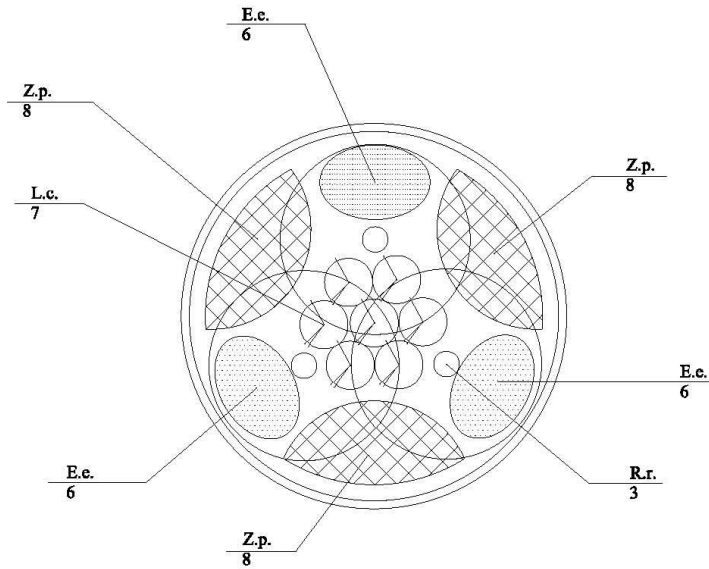

PLANT LIST				
SYMBOL	BOTANICAL(COMMON NAME)	DESCRIPTION	QUANTITY	COMMENTS
PALMS				
R.r.	<i>Roystonea regia</i> (Florida Royal Palm)	6' GW, FG	3	N / FF
SHRUBS				
L.c.	<i>Loropetalum chinense</i> (Chinese Fringe Bush)	14-18"H x 16-20"Spr., 3 gal., 36"OC, Full	7	FF
GROUNDCOVERS				
E.e.	<i>Eragrostis elliotii</i> (Elliott Love Grass)	8-12"H & Spr., 1 gal., 24"OC, Full	18	N / FF
Z.p.	<i>Zamia pumila</i> (Coarctic)	12-16"H x 14-18"Spr., 3 gal., 30"OC, Full	24	N / FF
MISCELLANEOUS				
	Melaleuca Mulch	3" Depth Min.	415 SF	
	Staking and Guying	Per Details	3 Palms	

PLANT LIST LEGEND
N - Native
FF - Florida Friendly

Cul-De-Sac - D1

Charlotte Engineering & Surveying, Inc.
 1700 El Jobean Road
 Port Charlotte, Florida 33948
 Telephone No: (841) 629-2552
 Fax No: (841) 743-8298

Burnt Store Village/Cul-De-Sac Landscape Enhancement Plans Charlotte County, Florida

Date: September 2013

Project No. 112690

SCALE: 1"=10'

Sheet:

—

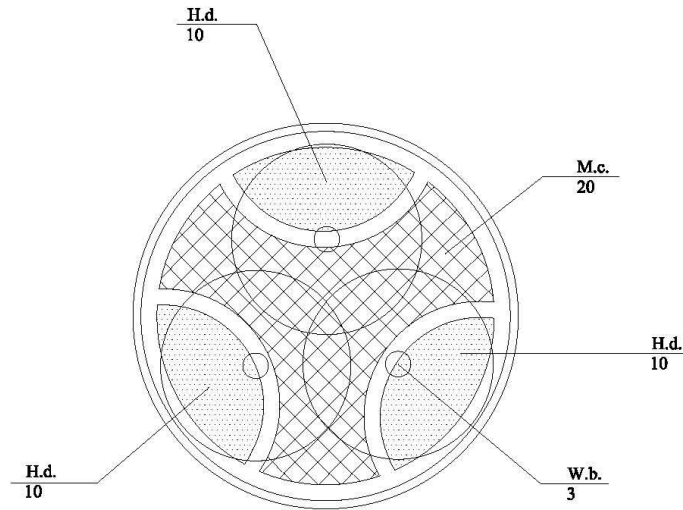

PLANT LIST				
SYMBOL	BOTANICAL(COMMON NAME)	DESCRIPTION	QUANTITY	COMMENTS
PALMS				
W.b.	<i>Wodyetia bifurcata</i> (Foxtail Palm)	16'OA, FG	3	FF
GROUNDCOVERS				
H.d.	<i>Helianthus debilis</i> (Dune Sunflower)	12-18"Spr., 1 gal., 24"OC, Full	30	N / FF
M.c.	<i>Muhlenbergia capillaris</i> (Muhly Grass)	24-30"H & Spr., 3 gal., 36"OC, Full	20	N / FF
MISCELLANEOUS				
	Melaleuca Mulch	3" Depth Min.	415 SF	
	Staking and Guying	Per Details	3 Palms	
PLANT LIST LEGEND				
N - Native				
FF - Florida Friendly				

Cul-De-Sac - D2

Charlotte Engineering & Surveying, Inc. 1700 El Jobean Road Port Charlotte, Florida 33948 Telephone No: (941) 629-2552 Fax No: (941) 743-8298	Burnt Store Village/Cul-De-Sac Landscape Enhancement Plans Charlotte County, Florida	Date: September 2013	Sheet: —
		Project No. 112690	
		SCALE: 1"=10'	

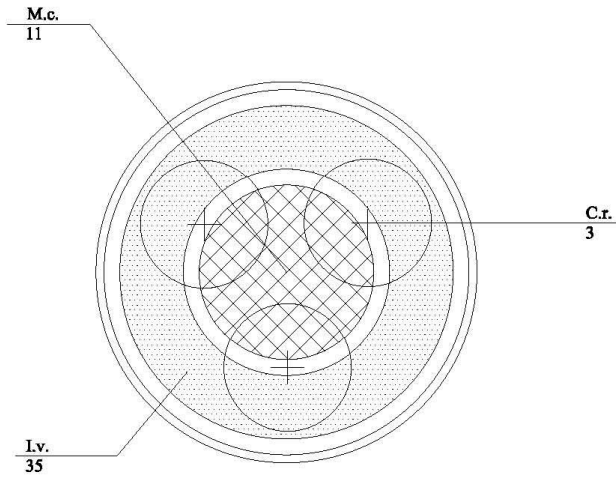

PLANT LIST				
SYMBOL	BOTANICAL(COMMON NAME)	DESCRIPTION	QUANTITY	COMMENTS
SMALL TREES				
C.r.	Callistemon 'Red Cluster'(Red Cluster Bottlebrush)	6-8'H x 4-5'Spr., 25 gal. Full	3	FF
GROUNDCOVERS				
Lv.	Ilex vomitoria 'Stokes Dwarf'(Dwarf Yaupon Holly)	8-12"H & Spr., 3 gal., 30"OC, Full	35	N / FF
M.c.	Muhlenbergia capillaris(Muhly Grass)	24-30"H & Spr., 3 gal., 36"OC, Full	11	N / FF
MISCELLANEOUS				
	Molalouca Mulch	3" Depth Min.	415 SF	
	Staking and Guying	Per Details	3 Trees	

PLANT LIST LEGEND
N - Native
FF - Florida Friendly

Cul-De-Sac - D3

Charlotte Engineering & Surveying, Inc. 1700 El Jobean Road Port Charlotte, Florida 33948 Telephone No: (941) 629-2552 Fax No: (941) 743-8298	Burnt Store Village/Cul-De-Sac Landscape Enhancement Plans Charlotte County, Florida	Date: September 2013	Sheet:
		Project No. 112690	—
		SCALE: 1"=10'	

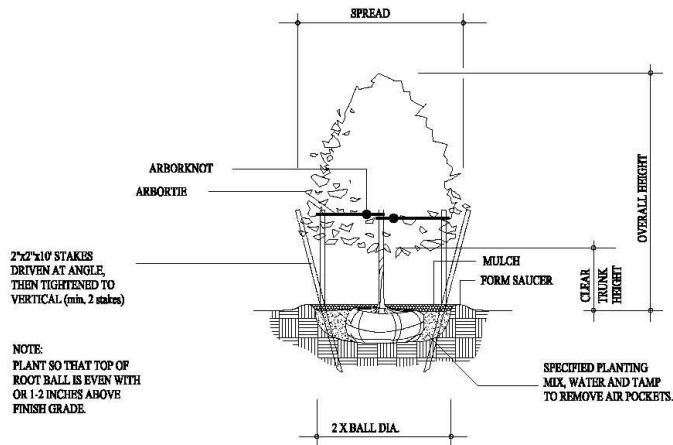

TREE PLANTING DETAIL(2" CALIPER OR LESS)

SCALE: NOT TO SCALE

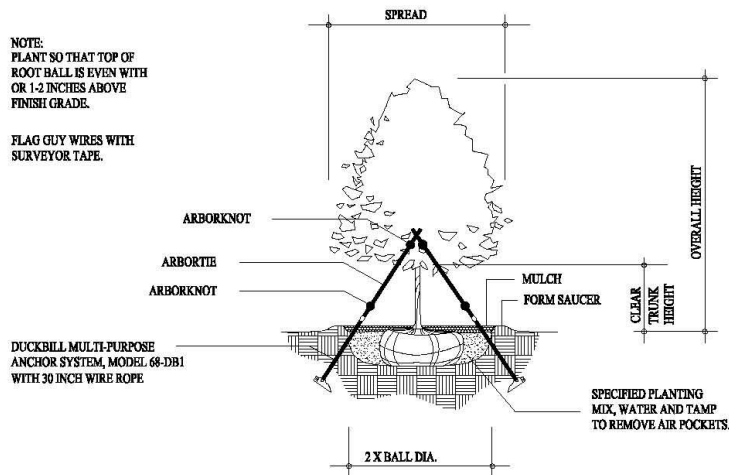

TREE PLANTING DETAIL(GREATER THAN 2" CALIPER)

SCALE: NOT TO SCALE

Planting Detail

Charlotte Engineering & Surveying, Inc. 1700 El Jobean Road Port Charlotte, Florida 33948 Telephone No: (941) 629-2552 Fax No: (941) 743-8298	Burnt Store Village/Cul-De-Sac Landscape Enhancement Plans Charlotte County, Florida	Date: September 2013	Sheet:
		Project No. 112690	
		SCALE: NTS	—

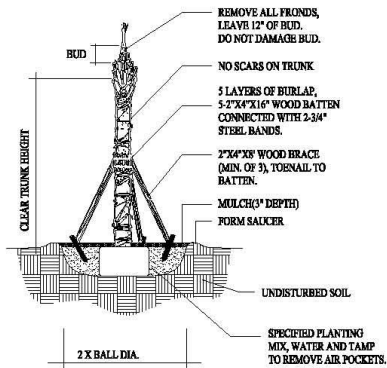

CABBAGE PALM PLANTING DETAIL
SCALE: NOT TO SCALE

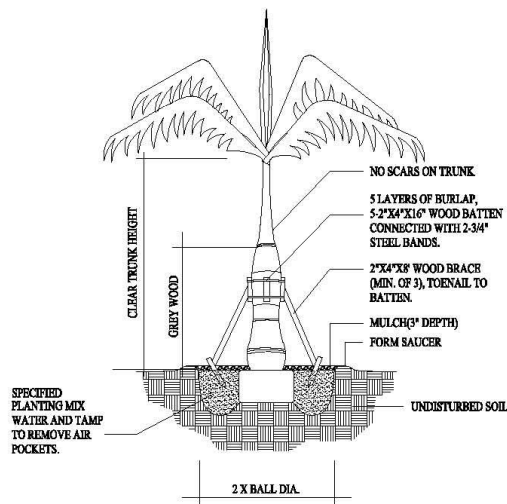

PALM PLANTING DETAIL
SCALE: NOT TO SCALE

Planting Detail

Charlotte Engineering & Surveying, Inc. 1700 El Jobean Road Port Charlotte, Florida 33948 Telephone No: (941) 629-2552 Fax No: (941) 743-8298	Burnt Store Village/Cul-De-Sac Landscape Enhancement Plans Charlotte County, Florida	Date: September 2013	Sheet:
		Project No. 112690	—
		SCALE: NTS	—

NOTE:
 PLANT SO THAT TOP OF
 ROOT BALL IS EVEN WITH
 OR 1-2 INCHES ABOVE
 FINISH GRADE.

SPECIFIED PLANTING
 MIX, WATER AND TAMP
 TO REMOVE AIR POCKETS.

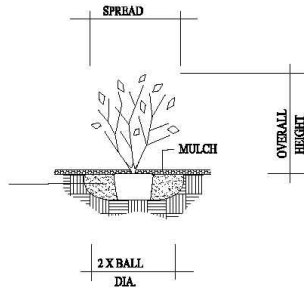

SHRUB & GROUNDCOVER PLANTING DETAIL

SCALE: NOT TO SCALE

Planting Detail

Charlotte Engineering & Surveying, Inc. 1700 El Jobean Road Port Charlotte, Florida 33948 Telephone No. (941) 629-2552 Fax No. (941) 743-6298	Burnt Store Village/Cul-De-Sac Landscape Enhancement Plans Charlotte County, Florida	Date: September 2013	Sheet: —
		Project No. 112690	
		SCALE: NTS	

SECTION 02900
LANDSCAPING

PART 1 – GENERAL

1.01 SCOPE OF WORK

- A. The CONTRACTOR shall furnish all materials, equipment, tools, transportation, services, and labor required for the complete installation of trees and plants of the species, size and quality in the locations indicated on the drawings or as approved by the LANDSCAPE ARCHITECT.

1.02 RELATED WORK REQUIREMENTS

- A. The Contract Documents include, but are not limited to, the following related requirements, if applicable.

1.03 SUBMITTALS

- A. Submit to the LANDSCAPE ARCHITECT for approval, shop drawings and complete written maintenance instructions for each type of plant furnished under the Contract.
- B. Submit representative samples of any and all required accessory planting materials as approved by the LANDSCAPE ARCHITECT.

1.04 GUARANTEE

- A. The CONTRACTOR shall furnish a written guarantee warranting all materials, workmanship and plant material.
- B. During the guarantee period, the CONTRACTOR shall replace at no cost to the OWNER, any plant required under the Contract that dies or is not established at the end of the guarantee period. All replacement plants shall be of like size and kind of the plants removed.
- C. The CONTRACTOR is not responsible for the replacement of plant material damaged through acts of vandalism or acts of nature, such as frost, flooding, fire etc.

- D. Trees and Palms shall be guaranteed for a period of 365 days after final acceptance. Replacement trees and palms shall be guaranteed for an additional 365 days.
- E. Shrubs, vines, and ground covers shall be guaranteed for 365 days after final acceptance. Replacement plant material shall be guaranteed for an additional 365 days.

1.05 STANDARDS

- A. All trees, shrubs and plants shall be true to name as established by the American Joint Committee on Horticultural Nomenclature publication "Standard Plant Names". The designated authority for the identification of all materials shall be the two publications of L. H. Bailey, Hortus II and Manual on Cultivated Plants, and all specimens shall be true to type, name, etc., as described herein.

1.06 QUALITY CONTROL

- A. All plants shall be nursery grown and shall comply with all required inspection grading standards, and plant regulations as set forth in the Florida Department of Agriculture, and "Grades and Standards for Nursery Plants", including revisions.
- B. The minimum grade for all trees and shrubs shall be Florida No. 1 unless otherwise indicated and all plants shall be sound, healthy and vigorous, well branched and densely foliated when in leaf. They shall have healthy, well developed root systems and shall be free of disease and insect pests, eggs or larvae. Plant material indicated as specimen shall be graded as Florida Fancy per "Grades and Standards for Nursery Plants".
- C. All plants shall conform to the measurements specified or indicated on the drawings. Plants larger than specified may be used but use of such plants shall not increase the contract price. The spread of roots or ball of earth for larger plants shall be increased in proportion to the size of the plant.
- D. The quantities indicated on the plant list are intended as a guide for comparison bidding and does not relieve the CONTRACTOR from providing a comprehensive material take off. In the event that a discrepancy occurs between the quantities listed in the plant list and the quantities indicated on the plan, the quantities indicated on the plan shall govern, and the contractor shall notify the LANDSCAPE ARCHITECT of the discrepancy.
- E. Substitutions will be permitted only upon submission of sufficient proof that any plant is not obtainable and upon authorization of the LANDSCAPE ARCHITECT.

Under no circumstances shall unauthorized substitutions be included in the bid proposal and breakdown.

1.07 PLANT DESIGNATION

- A. With reference to methods of cultivation, root system status, etc., plants for landscaping shall be classified under the following designations:
1. Balled and Burlapped: Plants so classified shall be dug with firm natural root ball of earth, of sufficient diameter and depth to include most of the fibrous roots. The root ball of these plants shall be properly wrapped with burlap sack material and remain protected and wet until they are planted. All balled and burlapped plants which cannot be planted immediately upon delivery shall be set on the ground and shall be well protected with soil, wet moss or other acceptable material. The plants shall be set with the burlap cover intact and with the burlap showing, until inspection. At final inspection the burlap shall be cut away to ground level and then completely covered with soil. All trees having cracked or broken balls and showing rope or cable damage or other improper handling will not be accepted.
 - a. As a specific requirement, balled and burlapped materials, 1.5" or more in caliper, shall be root pruned at least 45 days before being dug and such fact shall be certified on accompanying invoices. Where, in the opinion of the LANDSCAPE ARCHITECT following his inspection of the grower's stock, adequate root pruning is being obtained by the growers general cultivating practices, he may consider such fact as meeting this requirement.
 2. Wired Balled and Burlapped: Plants grown in soil of a loose texture which does not readily adhere to the root system shall have sound hog wire placed around the burlapped ball before the plant is removed from the excavation. The wire shall be looped and tensioned until the burlapped ball is substantially packaged so as to prevent loosening of the soil around the roots during handling. Wire balled and burlapped plants shall otherwise comply with the requirements for balled and burlapped plants described above.
 3. Container Grown Plants: Container grown plants shall have been grown in a container large enough and for sufficient time for the root system to have developed well enough to hold the soil together firm and whole. No plants shall be loose in the container. Plants which have become pot bound or for which the root system is too large for the size of the container, will not be acceptable.
 - a. All containers shall be cut and opened fully, in a manner such as will not damage the root system. Container grown plants shall not be removed from the container until immediately before

- planting, when all due care shall be taken to prevent damage to the root system.
- b. Container grown plants with excessive roots shall be root pruned with a sharp sterile tool in four equally spaced areas around the circumference of the root ball, to disrupt the circular pattern of the roots. Loosen the roots adjacent to the cut roots to encourage root spread.
4. Palms: All plants of the Palmacea Family shall have the roots adequately wrapped before transporting except when they are container grown. Burlapping will not be required if the palm is carefully dug from marl or heavy soil that adheres to the roots and retains its shape without crumbling. During transporting and after arrival, root balls of palms shall be carefully protected from wind and exposure to the sun. Palms not planted within 12 hours after delivery to the job site, shall have their root ball covered with a moist material and the palm bud shall not be allowed to dry out.
 - a. Transporting of palms shall be executed in accordance with the provisions for Heavy Trunk Palms, as prescribed in "Florida Grades and Standards for Nursery Plants, Part II".
 5. All plants shall be dug and handled in a manner that will not cause any damage to the branches, shape, and future development of the plants. All plants shall be handled so that roots are adequately protected at all times from drying out and from injury. The balls of balled plants that cannot be planted immediately on delivery shall be well protected with soil or other acceptable material. Bare root plants shall be planted or healed-in immediately upon delivery. Trees moved by winch or crane shall be thoroughly protected from chain marks, girdling or bark slippage by means of burlap, wood battens or other approved method. Canopy trees, such as oaks, shall be defoliated prior to being transported, if so directed by the LANDSCAPE ARCHITECT.

1.08 TRANSPORTATION AND INSPECTION

- A. Plant transportation shall comply with all Federal, State, County, and City regulations therefore and upon delivery at the site. All plants shall be inspected for conformity to the specifications and for handling damage. Rejected plants shall be immediately removed from the site and replaced with acceptable plants by the CONTRACTOR.

1.09 FIELD ENGINEERING

- A. The CONTRACTOR shall be responsible for all field engineering required for the proper installation of all work within this section of the Contract.

1.10 PERCOLATION TESTS

- A. The CONTRACTOR shall provide percolation tests as may be directed by the LANDSCAPE ARCHITECT as follows:
1. Wait at least 24 hours after rain and dig test pit 12 inches square or 13 1/2 inches in diameter to depth of bottom of plant bed and remove all loose soil. (If standing water is visible, notify the LANDSCAPE ARCHITECT).
 2. Quickly fill pit bottom with 6 inches (approximately 3 1/4 gallons) of water.
 3. Record length of time from filling until disappearance of water and divide number of minutes by 6 to give average time of 1 inch fall.
 4. Compare 1 inch fall time with the following table:

1 inch in 0-3 minutes indicates rapid absorption.
1 inch in 3-5 minutes indicates medium absorption.
1 inch in 5-30 minutes indicates slow absorption.
1 inch in over 60 minutes indicates impervious soil.
- B. Planting shall not begin until planting area drainage has been approved by the LANDSCAPE ARCHITECT.

1.11 ABBREVIATIONS

B&B	Balled and Burlapped
B.R.	Bare Root
Bl.	Bloom
Cal.	Caliper
Cn.	Container
C.T.	Clear Trunk measured from the top of the ball to the first branching of fronds.
C.W.	Clear Wood
DBH.	Diameter at Breast Height
E.C.	Egg Can
Esp.	Espaliered
F.	Full
F.F.	Florida Fancy
F.G.	Field Grown
Gal.	Gallon Container
G.B.	Grow Bag
H.	Height of foliage above the root ball.
H.B.	Hanging Basket
Hvy.	Heavy
L.	Lerio Container (10 gal.)

Ln.	Liner
Mlt.	Multiple
Ms.	Multi-stem
OA.	Overall height measured from the top of the ball to the midpoint of the current season's growth.
ppp.	Plants per pot.
Pts.	Pint Container
Qts.	Quart Container
R.C.	Rooted Cuttings
Sc.	Sculpture
Sdlg.	Seedling
Sh.	Shade Grown
Sn.	Sun Grown
Sp.	Specimen (shall be Florida Fancy)
Spr.	Spread
Std.	Standard
Tf.	Tree-form
Var.	Variety
W.	Width of plant material.

PART 2 - PRODUCTS

2.01 MATERIALS

- A. Topsoil for planting holes shall be "Planting Mix" as provided by Hillary Peat Company, (800) 608-3276, or equivalent. "Planting Mix" shall consist of sixty (60) percent Florida Fibrous Peat, twenty (20) percent Compost, and twenty (20) percent Sand.
- B. TERRA-SORB, moisture retaining polymer, as manufactured by Industrial Services International, Inc. or equivalent.
- C. Mulch type is specified in the Plant List and shall not contain sticks larger than 1/4 inch in diameter, stones or other foreign material that will prevent the eventual decay of the mulch necessary for its complete effectiveness.
- D. Duckbill, multi-purpose anchor system, Model 68-DB1, with thirty (30) inch wire rope, manufactured by Foresight Products, Inc. or equivalent.
- E. Arbortie, 3/4 inch wide, green, flat woven polypropylene material, manufactured by Deep Root Partners, L.P. or equivalent.

PART 3 - EXECUTION

3.01 LAYOUT OF PLANTINGS

- A. Locations for plants and outlines of areas to be planted are indicated on the plans and shall be marked on the ground by the CONTRACTOR and approved by the LANDSCAPE ARCHITECT before any excavation or planting is executed.

3.02 PROTECTION OF PLANTING AREAS

- A. Before excavations are made, precautionary measure shall be taken to protect all turf areas that are to be trucked over and upon which soil is to be temporarily stacked and beds that are to be preserved shall be barricaded in a manner to afford effective protection during planting operation.

3.03 HERBICIDE TREATMENT

- A. Unless otherwise specified on the plans, the CONTRACTOR shall eradicate all existing grass and weeds by treating with "Round-Up" or approved equal. The CONTRACTOR shall follow the MANUFACTURER's instructions for mixture rates and application rates. Planting bed preparation shall not begin until all of the existing grass and weed vegetation is killed.

3.04 UNDERGROUND OBSTRUCTIONS

- A. The CONTRACTOR will be responsible to secure underground locations from the public utility companies, such as telephone, electricity, cable TV, etc.
- B. In the event that rock, underground construction work, utility lines or obstructions out of the ordinary are encountered in any plant pit excavation, alternative locations shall be selected by the LANDSCAPE ARCHITECT. Where locations cannot be moved, and the obstructions may be removed, the obstruction shall be removed to a depth of not less than 3 feet below grade and not less than 6 inches below bottom of balls or roots when the plant is properly set at the required grade.

3.05 EXCAVATION OF PLANT HOLES

- A. All planting beds shall have two (2) inches of "Planting Mix" incorporated into the top six (6) inches of existing soil.
- B. All planting holes shall have straight vertical sides and flat horizontal bottoms. The diameter of a hole, shall be filled with planting mixture as specified above,

thoroughly mixed with natural soil at the rate of fifty (50) percent Planting Mix and fifty (50) percent natural soil. Soil shall be free of coarse sand, stones, lumps, sticks or other foreign materials that might be harmful to plant growth. Incorporate TERRA-SORB into each planting hole at the rates recommended by the MANUFACTURER.

3.06 SETTING OF PLANTS

- A. When lowered into the planting hole, the plant shall rest on virgin soil, so that the roots are level with, or slightly above, the level of their previous growth and oriented to present the best appearance. The CONTRACTOR, when setting plants into the holes, shall make allowances for any anticipated settling of the plants.
- B. Backfill around the rootball with "Planting Mix" to the depths specified in the "STANDARD CHARLOTTE COUNTY LANDSCAPE PLANTINGS INSTALLATION & MAINTENANCE SPECIFICATIONS" item No. 28. The natural soils shall be free of coarse sand, stones, lumps, sticks or foreign materials that might be harmful to plant growth. The backfill shall be watered-in and rodded to eliminate air pockets, after 50 percent filled and 100 percent filled. Plants shall be kept in a moistened condition for the duration of the planting operation period.
- C. A watering saucer shall be made around all trees and palms and shall remain through the warranty period, at which time the CONTRACTOR shall remove the excess soil forming the saucer. Acceptable excess excavated topsoil shall be used to form saucers around plants or spread uniformly over low areas or otherwise disposed of as approved by the LANDSCAPE ARCHITECT. Excess soils not required or not suitable for the above usage shall be disposed of by the CONTRACTOR.

3.07 STAKING AND GUYING

- A. Plants shall be staked in accordance with the following provisions:
 - 1. Trees: All trees other than palm trees shall be staked or guyed based on the trees size. Refer to the Tree Planting Details for specific staking and guying information. Remove all stakes and guys at the end of the warranty period.
 - 2. Palm Trees: Palms shall be braced with three 2 inch by 4 inch wood braces, toenailed to cleats which are securely banded at three points to the palm, at a point 1/3 the height of the trunk. The trunk shall be padded with five layers of burlap under the cleats. Braces shall be approximately 120 degrees apart and secured underground by 2 inch by 4 inch by 24 inch stake pads, as directed by the LANDSCAPE ARCHITECT.

3.08 PRUNING

- A. Make all cuts with a sharp sterile instrument, flush with the trunk or adjacent branch in such a manner as to insure the elimination of stubs. "Headback" cuts at right angles to the line of growth will not be permitted and trees will not be accepted.
- B. All broken or damaged roots shall be cut off smoothly in a manner complying with standard horticultural practice. At the time pruning is completed, all remaining wood shall be alive.

3.09 MULCHING

- A. Within one week after planting, mulch material, shall be uniformly applied to a minimum loose thickness of 3 inches over the entire area of the backfilled hole or bed. The mulch shall be maintained continuously in place until the time of final inspection. Existing trees and shrub areas to remain shall be mulched to a depth of 2 inches.

3.10 EXISTING VEGETATION

- A. Protect designated vegetation to remain with a temporary wooden fence not less than 3 feet in height composed of lumber made of no less than 2 inch by 2 inch for shielding of existing vegetation from the movement of construction equipment, debris and/or fill.
- B. Protect against insects and disease, injury or damage, including cutting, breaking or skinning of roots, trunks or branches, smothering by stockpiled construction materials, excavated materials or vehicular traffic within the branch spread. Repair vegetation damaged by construction operations in a manner acceptable to the LANDSCAPE ARCHITECT.
- C. Where building or paving occurs within the branch spread, the CONTRACTOR shall root prune those roots affected by the construction. Roots shall be cleanly pruned to an elevation deep enough to avoid tearing of the roots 18 inches beyond the excavation area.
- D. Replace vegetation scheduled to remain that are damaged beyond repair by construction operations, as determined by the LANDSCAPE ARCHITECT, with vegetation of similar size and species, at no additional cost to the OWNER.
- E. Prune dead limbs and/or fronds, and clean up existing vegetation to remain unless otherwise shown or noted on the Drawings.

3.11 EXISTING TREES

- A. Protect designated trees to remain with a temporary wooden fence not less than 3 feet in height composed of lumber made of no less than 2 inch by 2 inch for shielding of existing trees from the movement of construction equipment, debris and/or fill.
- B. Protect against insects and disease, injury or damage, including cutting, breaking or skinning of roots, trunks or branches, smothering by stockpiled construction materials, excavated materials or vehicular traffic within the branch spread. Repair trees damaged by construction operations in a manner acceptable to the LANDSCAPE ARCHITECT. Repair damaged trees promptly to prevent progressive deterioration caused by damage.
- C. Where building or paving occurs within the branch spread, the CONTRACTOR shall root prune those roots affected by the construction. Roots shall be cleanly pruned to an elevation deep enough to avoid tearing of the roots 18 inches beyond the excavation area. Interfering branches of trees scheduled to remain may be removed by a professional arborist when acceptable to the LANDSCAPE ARCHITECT.
- D. Measure the soil pH around the existing trees to remain and maintain same throughout construction.
- E. Replace trees scheduled to remain that are damaged beyond repair by construction operations, with trees of similar size and species, at no additional cost to the OWNER. If the tree is too large to replace, then the OWNER will be reimbursed for the tree. Cost for tree replacement shall be determined in accordance with the Tree Evaluation Formula as described in "A Guide to the Professional Evaluation of Landscape Trees, Specimen Shrubs and Evergreens", published by the International Society of Arboriculture.
- F. Selectively prune existing trees in designated areas, under the direction of the LANDSCAPE ARCHITECT. Remove sucker shoots, dead, rubbing and damaged branching.
- G. Water disturbed existing trees every week until final acceptance. Water thoroughly with a fine mist sprinkler head, soaker hose or hose at a low flow rate over the entire drip line area as required to allow water to penetrate to a depth of 12 to 18 inches.

- H. Clearing and grading adjacent to existing trees:
 - 1. Treat area with "Round-Up" herbicide using MANUFACTURER's recommendations for mixing and application.
 - 2. Use hand methods for grubbing inside the drip line of trees to remain. Strip grass materials to a maximum depth of 1 inch under tree canopies. Carefully till or scarify existing grade to a depth of 1 inch.
 - 3. Consult with LANDSCAPE ARCHITECT prior to grading operations around existing trees to remain.
 - 4. Perform grading within barricaded areas of existing trees to remain by hand methods to elevations indicated.
 - 5. Cut roots cleanly to depth of 3 inches below proposed finish grade.

- I. Filling adjacent to existing trees:
 - 1. Minor fills of 4 inches or less: Fill with topsoil; hand grade to required finish grade elevation.
 - 2. Moderate fills of 12 inches or less: Place a layer of 3/4 to 1 1/2 inches crushed stone or gravel on grade, at 1/2 of the fill height, but not less than 3 inches. Cover drainage fill with polypropylene filter fabric. Fill remaining depth with sandy loam topsoil; hand grade to required finish grade elevations. Do not place topsoil fill in contact with the tree trunk; maintain a minimum of 18 inch radius from the tree trunk of undisturbed natural grade.
 - 3. Fill over 12 inches but less than 18 inches: Place a layer of 3/4 to 1 1/2 inch crushed stone or gravel on grade. Extend stone or gravel fill to the drip line of the tree and to within 4 inches of the required finish grade. Cover the drainage fill with polypropylene filter fabric. Fill remaining depth with sandy loam topsoil; hand grade to required finish grade elevation. Do not place topsoil fill in contact with the tree trunk; maintain a minimum of 18 inch radius from the tree trunk of undisturbed natural grade. Provide 4 inch tile drainage system and vents.
 - 4. Deep fills over 18 inches: Place a 4 inch depth of 1 to 2 inch crushed stone or gravel fill on grade, extending to the outer branch drip line around the tree branch perimeter. Cover with 3/4 to 1 inch crushed stone or gravel to within 6 inches of the required finish grade. Cover drainage fill with polypropylene filter fabric. Fill the remaining depth with sandy loam topsoil; hand grade to required finish grade elevation. Do not place earth fill in contact with tree trunk; maintain 18 inch radius of undisturbed natural grade. Provide tile drainage system.

- J. Utilities installation adjacent to existing trees:
 - 1. Proposed utility lines for water, irrigation, electric, telephone and sanitary sewer lines shall be tunneled through the roots of the existing trees to remain when realignment is not an acceptable alternative.

2. Waste water sewer lines shall be aligned to avoid the drip line of existing trees to remain. If the above is not possible, then the tree or trees shall be root pruned prior to trenching.

3.12 TREE RELOCATION

- A. Transplant trees designated for relocation to locations shown on the Drawings. Prune, dig, ball and burlap, move and plant in accordance with specified tree planting requirements.
- B. Prune, dig, ball and burlap, and move designated tree for relocation to the designated plant storage area for healing in of materials until final planting areas are prepared.
- C. Maintain plants in storage areas by bracing plants in vertical position and setting balls in an enclosed berm of topsoil or bark. Water as needed to maintain adequate root moisture.
- D. Reburlap plant balls if required before final transplanting operations.
- E. Move to final locations shown on the Drawings and plant in accordance with specified tree planting requirements.

3.13 MAINTENANCE

- A. Maintenance shall begin immediately after each plant is planted and shall continue until final acceptance by the OWNER. Plants shall be watered, mulched, weeded, pruned, sprayed for insects, disease and fungus, fertilized, cultivated and otherwise maintained and protected.
- B. The following maintenance shall be provided by the CONTRACTOR until the end of the guarantee period: the resetting of settled plants to proper grade position, restoring planting saucers and removal and replacement of dead or unacceptable material. Guys shall be kept tightened and repaired. Defective work shall be corrected within two weeks of notification. Also included in the maintenance are those items required by item No. 26 of the "STANDARD CHARLOTTE COUNTY LANDSCAPE PLANTINGS INSTALLATION & MAINTENANCE SPECIFICATIONS".
- C. Upon acceptance of the landscape installation the CONTRACTOR shall supply the OWNER with a complete and adequate maintenance program to be followed during and after the guarantee period.

- D. The CONTRACTOR shall make frequent inspections on the job during the guarantee period to determine if proper maintenance is being given.
- E. It shall be understood that in accordance with the terms of the guarantee that the CONTRACTOR must promptly inform the OWNER if proper maintenance is not being given to the installation. Such notice shall be in writing outlining corrective measures to be taken with a copy to the LANDSCAPE ARCHITECT.

3.14 FINAL INSPECTION

- A. At the time of final completion, an inspection of plants will be made by the LANDSCAPE ARCHITECT upon written notice requesting such inspection, submitted by the CONTRACTOR at least five days before the anticipated inspection. All defects discovered shall be repaired or replaced by the CONTRACTOR within two weeks.

3.15 CLEANING UP THE SITE

- A. Upon completion of the project, the CONTRACTOR must thoroughly clean up the project site, removing all equipment, unused materials, detrimental material, and surplus excavated material. The CONTRACTOR shall provide a neat and uniform site. All damaged or altered existing structures, as a result of the landscape work, shall be corrected by the CONTRACTOR at no expense to the OWNER.

END OF SECTION

STANDARD CHARLOTTE COUNTY LANDSCAPE PLANTINGS INSTALLATION & MAINTENANCE SPECIFICATIONS:

THIS AND ALL PLANS PAGES, AS WELL AS THE REQUEST FOR BIDS OR QUOTES CONSTITUTE THE CONTRACT, NEITHER IS COMPLETE WITHOUT THE OTHER.

1. PROVIDE MATERIALS, EQUIPMENT, TOOLS, TRANSPORTATION, SERVICES AND LABOR TO ACCOMPLISH THE INSTALLATION OF SPECIFIC LANDSCAPE PLANTING PLANS DEVELOPED BY THE COUNTY, ANY DEVIATION FROM SPECIFIED PLANT SELECTION, SIZE OR SPACING MUST BE PRE-APPROVED BY THE COUNTY. PLANT STOCK SPACING, BOTH ON CENTER AND FROM BED EDGES, MUST MATCH MEASUREMENTS ON THE SCALE DRAWING/PLAN PROVIDED BY THE COUNTY.
2. PERFORM SITE ANALYSES AND PREPARATORY WORK NECESSARY TO ACCOMMODATE LANDSCAPE INSTALLATION, IN ACCORDANCE WITH CURRENT STANDARDS OF THE FLORIDA NURSERY GROWER'S AND LANDSCAPE ASSOCIATION. THIS MAY ENTAIL REMOVAL OF SIGNIFICANT AMOUNTS OF UNSUITABLE SOIL AND OTHER MATERIALS AND REPLACEMENT WITH HIGH QUALITY TOP SOIL, SOIL CONDITIONERS AND SOIL AMENDMENTS.
3. IF APPLICABLE, REMOVE AND DISPOSE OF OR RELOCATE AND TRANSPLANT EXISTING PLANT MATERIALS. PRESERVATION AND TRANSPLANTING OF SUCH MATERIALS IS TO BE DONE IN A MANNER CONSISTENT WITH CURRENT RECOMMENDATION OF UF/IFAS AND FNGLA.
4. INSTALL ALL PLANTS, TREES AND PALMS IN A MANNER CONSISTENT WITH CURRENT RECOMMENDATIONS BY THE UNIVERSITY OF FLORIDA COOPERATIVE EXTENSION SERVICE AND THE FLORIDA NURSERY GROWERS AND LANDSCAPE ASSOCIATION. SOD AND SODDING ARE TO MEET CURRENT STANDARDS OF THE FLORIDA TURF GRASS ASSOCIATION.
5. WATER ABSORPTIVE OR WATER MANAGEMENT CRYSTALS SUCH AS HORTA-SORB OR TERRA-SORB AND MYCORRHIZAL FUNGI PLUS BENEFICIAL BACTERIA PRODUCTS SUCH AS PHC TREE SAVER AND PHC PLANT SAVER ARE TO BE INCORPORATED INTO ALL PLANTING HOLE BACK FILL SOILS, PER MANUFACTURER INSTRUCTIONS.
6. SUPPLY "SHOP DRAWINGS"/PRODUCT SPECIMEN LABELS AND ANALYSIS REPORTS OF ALL NON-PLANT MATERIALS TO BE UTILIZED. I.E. SOILS; SOIL ADDITIVES; MULCH; PESTICIDES; FERTILIZERS; IRRIGATION SYSTEM COMPONENTS; TREE AND PALM SUPPORTS.
7. IF APPLICABLE, INSTALL IRRIGATION SYSTEM; WELLS; PUMP STATIONS; CONTROLLERS AND ALL OTHER APPROPRIATE COMPONENTS, ACCORDING TO CURRENT STANDARDS OF THE FLORIDA IRRIGATION SOCIETY AND IN COMPLIANCE WITH THE SOUTHWEST FLORIDA WATER MANAGEMENT DISTRICT, AS WELL AS THE RESPECTIVE WATER UTILITY COMPANY.

8. PROVIDE MAINTENANCE OF TRAFFIC ACCORDING TO CURRENT CHARLOTTE COUNTY POLICY STANDARDS.
9. PRECIPITATE UTILITIES LOCATION SERVICE, PRIOR TO BEGINNING EXCAVATION WORK AND AS REQUIRED THEREAFTER.
10. OBTAIN NECESSARY PERMITS FOR PERFORMING THE WORK IN THE PUBLIC RIGHT OF WAY.
11. PERFORM INITIAL, THOROUGH WATERING – IN OF ALL PLANT MATERIALS, ALLEVIATING ALL AIR POCKETS IN BACK FILL SOIL.
12. SUPPORT TREES AND PALMS, ACCORDING TO CURRENT FNGLA RECOMMENDATIONS AND THOSE OF UF/IFAS. ASCERTAIN THAT ALL STAKING MATERIALS ARE INSTALLED WITHIN BEDS OR RINGS, NOT INTERFERING WITH TURF GRASS MAINTENANCE.
13. ALL PLANT MATERIALS ARE TO BE OF FLORIDA #1 GRADE OR BETTER PER CURRENT FLORIDA DEPARTMENT OF AGRICULTURE AND CONSUMER SERVICES, DIVISION OF PLAN INDUSTRY 'GRADES AND STANDARDS FOR NURSERY STOCK' AND FREE OF PLANT PESTS AND PLANT DISEASES. AT THE TIME OF FINAL ACCEPTANCE, ALL PLANT MATERIALS ARE TO APPEAR VIABLE AND HEALTHY UPON INSPECTION BY THE COUNTY'S DESIGNEE.
14. PROTECT PLANT MATERIALS, IN TRANSPORT AND ON SITE, FROM DESICCATION, WILTING AND BREAKAGE.
15. CREATE MULCH BERMS AROUND ALL TREE AND PALM PLANTING HOLES, INCLUDING THOSE WITHIN BEDS TO DIRECT WATER TO ROOT MASSES.
16. MULCH BEDS AND RINGS UNIFORMLY WITH 3" (AFTER SETTLING) OF SPECIFIED MULCH. KEEP MULCH AWAY FROM ALL STEMS AND TRUNKS.
17. REMOVE ALL NURSERY TAGS, LABELS, WIRES, TIES, FASTENERS, CONTAINERS, FABRICS, ROPES, STRINGS, NURSERY STAKES AND OTHER UNNECESSARY, DELETERIOUS MATERIALS FROM ALL PARTS OF ALL PLANT STOCK, BOTH UNDERGROUND AND ABOVE GROUND.
18. REPAIR OR PRECIPITATE REPAIR, AT NO EXPENSE TO THE COUNTY, OF ANY PROPERTY DAMAGED IN THE PROCESS OF PERFORMING WORK RELATED TO THE PROJECT.
19. ALL EQUIPMENT AND UNINSTALLED SUPPLIES ARE TO BE REMOVED FROM COUNTY PROPERTY UPON COMPLETION OF EACH DAY'S WORK.
20. ALL SOIL AND DEBRIS IS TO BE REMOVED FROM ALL PAVEMENT, UPON COMPLETION OF EACH DAY'S WORK.

21. BEST MANAGEMENT PRACTICES ARE TO BE EFFECTIVELY EMPLOYED, AS RELATED TO STORM WATER, EROSION, SEDIMENTATION AND TURBIDITY CONTROL, IN ACCORDANCE WITH CURRENT FLORIDA DEPARTMENT OF ENVIRONMENTAL PROTECTION GUIDELINES.
22. LOAD, HAUL AND DISPOSE OF EXCAVATED SOD, SOIL AND DEBRIS GENERATED, AT NO ADDITIONAL EXPENSE TO THE COUNTY.
23. RESTORE ALL TURF GRASS DISTURBED INCIDENTALLY IN PERFORMANCE OF THE WORK ADJACENT TO THE LANDSCAPE PLANTING AREA.
24. FERTILIZATION OF ALL PLANT MATERIALS WITH A GRANULAR PRODUCT SUCH AS 8-2-10 PLUS A COMPLETE MICRONUTRIENT PACKAGE IN THE MANNER AND AT THE RATE PRESCRIBED BY THE LABEL. APPLICATION MUST ALSO BE MADE IN ACCORDANCE WITH THE CHARLOTTE COUNTY FERTILIZER ORDINANCE.
25. PROVISION OF A ONE YEAR REPLACEMENT WARRANTY ON ALL PLANT MATERIALS IS REQUIRED.
26. MAINTENANCE ASSOCIATED WITH THE PLANTINGS AND, IF APPLICABLE, IRRIGATION EQUIPMENT, WITHIN THE ONE YEAR WARRANTY PERIOD, INCLUDES: WEED CONTROL; PLANT PEST AND DISEASE/DISORDER CONTROL; FERTILIZATION; PRUNING; TREE/PALM SUPPORT MAINTENANCE; EDGING; REMULCHING; LITTER & DEBRIS REMOVAL AND ALL OTHER TASKS NECESSARY FOR PROTECTION OF THE PERISHABLE ASSET.
27. A PUNCH LIST OF MINOR ITEMS MAY BE GIVEN TO THE CONTRACTOR FOLLOWING SUBSTANTIAL COMPLETION INSPECTION. ALL ITEMS ARE TO BE SATISFIED WITHIN 7 DAYS.
28. LANDSCAPE SOIL SPECIFICATIONS:

SOILS PLACED IN ROADWAY MEDIANS OR OTHER ROADSIDE SITES, IN PREPARATION FOR TREE; TURF AND LANDSCAPE PLANTINGS ARE TO MEET THE FOLLOWING SPECIFICATIONS, SO THE BEST CHANCE OF SUCCESS CAN BE ACHIEVED IN MAINTAINING VIABILITY OF THE INSTALLED PLANT MATERIALS.

- PH OF 5.5 TO 6.5, I.E. SLIGHTLY ACIDIC
- ORGANIC MATTER CONTENT BETWEEN 2 AND 6%
- NO LESS THAN 10% CLAY PARTICLES
- INFILTRATION AND PERCOLATION/DRAINAGE RATE OF 2" PER HOUR MINIMUM
- FREE OF NOXIOUS WEED SEEDS AND PROPAGULES; STICKS; ROCKS; LITTER AND OTHER MATERIALS AND PHYTOTOXINS DELETERIOUS TO HORTICULTURAL PLANTINGS
- BE OVERALL SUITABLE FOR THE THRIVING VIABILITY OF THE SELECTED PLANT MATERIALS

THESE MAY BE NATIVE, NATURAL TOP SOILS OR PLANT BED FILL SOILS CONDITIONED AND AMENDED TO MEET THE REQUIREMENTS. THE AWARDED CONTRACTOR SHALL SUBMIT TO THE COUNTY A SOIL ANALYSIS REPORT FROM A REPUTABLE HORTICULTURAL/AGRONOMIC TESTING LABORATORY REFLECTING THIS. ALL LOADS INSTALLED SHALL BE OF THE SAME QUALITY. DEPTH OF THIS SOIL IS TO BE 12" MINIMUM FOR SHRUBS AND GROUND COVER PLANTS; UP TO 30" FOR TREES AND TREE-LIKE PALMS.

29. ESTABLISHMENT WATERING: (SEE ESTABLISHMENT WATERING SCHEDULE)

NO PERMANENT IRRIGATION WILL BE PROVIDED. THE CONTRACTOR SHALL WATER ALL PLANT MATERIALS IMMEDIATELY AFTER PLANTING AND CONTINUE WATERING UNTIL ACCEPTANCE BY THE OWNER. THEREAFTER THE CONTRACTOR SHALL WATER ALL PLANT MATERIALS BASED ON THE FOLLOWING SCHEDULE. THE CONTRACTOR SHALL FURNISH ALL MATERIALS NECESSARY TO ACCOMPLISH THE WATERING OF THE PLANT MATERIALS. THE CONTRACTOR SHALL PROVIDE WATER FROM A FRESH WATER SOURCE. NO SALT OR BRACKISH WATER SHALL BE USED. ALTERNATIVE WATERING METHODS MAY BE UTILIZED IF ACCEPTABLE TO CHARLOTTE COOUNTY.

ESTABLISHMENT WATERING SCHEDULE	
WEEK 1	DAILY
WEEK 2 – WEEK 4	3 TIMES PER WEEK
WEEK 4 – WEEK 12	2 TIMES PER WEEK
WEEK 13 – WEEK 24	1 TIME PER WEEK
WEEK 25 – WEEK 52	AS NEEDED/MINIMUM TWICE PER MONTH

MAINTENANCE

HARDSCAPE MAINTENANCE: walking paths; gazebos; arbors and the like plus parking areas maintenance, such as weed control; debris removal; incidental trash removal and keeping a clear, safe passage for pedestrians and motorists.

MOWING OF MEDIANS: incidental litter removal, complete beautification quality mowing, mechanical edging, string trimming and blowing of debris from pavement; All mowing shall be done with sharp blades, at a cutting height of at least 4 inches and otherwise in accordance with current recommendations of the Florida Turf Grass Association.

TURF GRASS MOWING: beautification quality mowing of all turf grass within the project limits, including string trimming where appropriate and mechanical edging of plant bed lines; tree/palm rings and various utility and infrastructure objects. All mowing is to be performed in accordance with current recommendations of the Florida Turf Grass Association.

TURF GRASS MANAGEMENT: comprehensive management of various lawn grasses, i.e. mowing, edging; string trimming; irrigating; fertilizing, weed control; control of soil and surface insect pests and diseases; thatch management; hydro-seeding; re-plugging or re-sodding; core aerating; top dressing and all else involved in turf grass management. The turf grass is to be kept virtually weed free at all times. Stressed areas are to be remediated in a timely manner to keep the turf from perishing and to provide consistent appeal. This work is to be performed in accordance with current recommendations of the Florida Turf Grass Association.

BED CARE: weed control to include control of all undesirable vegetation within the beds and among plants, keeping plantings virtually weed free at all times; removal and replacement of dead and unviable plant materials including trees and palms; plant debris removal; edging; litter removal; soil and mulch grooming in order to keep beds neat and attractive. Encroaching brush is to be treated as weeds and kept outside of bed areas. This work is to be performed in accordance with current recommendations of the Florida Nursery Growers and Landscape Association, as well as the Florida Pest Management Association.

TREE PRUNING: proper pruning, only as necessary, for public safety and tree health; All tree pruning, including timing thereof, is to be performed in accordance with current recommendations of the International Society of Arboriculture.

FERTILIZATION: application of granular fertilizer over the root zone of all plants; trees and palms. The product applied must be of an acceptable grade/analysis including a complete micronutrient package, and be broadcast uniformly at the recommended rate in product label instructions. All fertilization is to be performed in accordance with the Charlotte County Fertilizer Ordinance.

FLOWER BED MANAGEMENT: bed preparation; seasonal and mid-crop removal and replacement of bedding plants to keep a consistently good visual appeal; fertilization; weed control; plant pest and plant disease control; irrigation and all else involved in effective management of thriving color rotation beds. Plant selection per rotation must be appropriate for seasonal conditions. This work is to be performed in accordance with current recommendations of the Florida Nursery Growers and Landscape Association.

IRRIGATION MANAGEMENT: total management of irrigation, i.e. system operation; scheduling; preventive maintenance and timely repair to achieve the intended result; elicit annual inspection of Reverse Pressure Backflow Assemblies (RPBA), where applicable, on irrigation systems, due each year. The contractor shall coordinate with the water utility and provide documentation to the county regarding verification of such inspection. In instances of need for significant repairs due to factors beyond the vendor's control, the contractor is to inform the County; timely repairs made and invoicing for such repairs submitted to the county with photos showing damages and repairs. During each scheduled service, the system must be turned on manually and each zone checked. All damaged or broken sprinkler heads; valves; zone lines; drip lines; bubblers or other emitters and main lines shall be repaired and/or replaced. Submit an invoice for other than incidental irrigation parts for reimbursement by the County. Contact the County representative prior to any major repairs above and beyond normal maintenance, i.e. damage due to vandalism; theft; accidents; acts of nature or other factors beyond the vendor's control. Submit a quote promptly to the County for prior approval of any major repairs. This work is to be performed in accordance with current recommendations of the Florida Irrigation Society and requirements of the Southwest Florida Water Management District, as well as Charlotte County's more stringent restrictions.

SUPPLEMENTAL WATERING: supplying and applying an adequate quality of water to drench the soil during dry times, using a water truck; tank or other means. Tree and plant root zones shall not be allowed to dry out excessively, causing wilting; foliar desiccation; growth stunting or death of plant materials. This work is to be performed in accordance with current local watering restrictions.

MULCHING: use of Florimulch (processed Melaleuca) to achieve and maintain a uniform; settled depth of three inches (3") of mulch. This work is to be performed in accordance with current recommendations of the Florida Nursery Growers and Landscape Association.

PALM PRUNING: proper removal of brown, dead fronds as well as all fruit and flower structures; no green or yellow fronds are to be removed or damaged. The bud is not to be damaged. This work is to be performed in accordance with current recommendations of the University of Florida Cooperative Extension Service.

PLANT HEALTH CARE: regular inspection and timely, effective management/treatment of plant pest insects; mites and plant diseases/disorders. When treatment is necessary, the least toxic and most target specific product will be chosen. Plant health care treatment products are to be applied at the rates specified by their manufacturers. This work is to be performed in accordance with current recommendations of all related educational and industry organizations.

PERIMETER BRUSH TRIMMING: keeping trees and other vegetation from encroaching on sites, affecting ability to perform other maintenance tasks. The site is to be kept the same size by such maintenance trimming.

FIRE ANT MANAGEMENT: effective treatment, resulting in virtually Fire Ant free spaces throughout project limits for public and worker safety at all times. This work is to be performed in accordance with current recommendations of the Florida Pest Management Association.

SHRUB AND PLANT PRUNING: proper removal of dead plant parts; thinning; heading back; rejuvenating; trimming; shearing; chemical plant growth regulation or otherwise properly pruning shrubbery; ground covers; ornamental grasses and other ornamental plant material, other than trees and palms, to achieve the intended aesthetic result. Major pruning is to be performed at the correct time of year, per plant type. This work is to be performed in accordance with current recommendations of the University of Florida Cooperative Extension Service.

GROUND COVER EDGING/PRUNING: proper removal of dead plant parts; thinning; heading back; rejuvenating; trimming; shearing; chemical plant growth regulation; mechanical edging; prudent mowing or otherwise properly pruning the ground cover plantings to achieve the intended aesthetic result and public safety. Ground cover plantings are to be kept neatly within medians or otherwise not interfering with roadway markings. Major pruning is to be performed at the correct time of year, per plant type. This work is to be performed in accordance with current recommendations of the University of Florida.

MANGROVE PRUNING: pruning of mangroves in accordance with Florida Department of Environmental Protection requirements and removal of invasive, exotic trees and plants.

REPLACEMENT, ESTABLISHMENT CARE AND WARRANTY OF TREES; PALMS AND PLANTS: Provide quotes to the County, within one week of request, for replacement and one year guarantee of (unacceptable) trees; palms and plants within the project limits. This work is to be performed in accordance with current recommendations of the University of Florida Cooperative Extension Service.

SIDEWALK MAINTENANCE: keeping sidewalks and adjacent hardscape assets (curbs, storm inlets and decorative pavers) virtually free of weeds. Prudent pruning of trees and other plant materials for safe passage is also required.

EMPTYING/CLEANING OF TRASH RECEPTACLES: disposal of contents and cleaning of all trash receptacles; the cans are to have heavy duty x-large trash liners replaced, each time they are emptied. They shall be emptied often enough to prevent foul odors; nuisance infestations and overflowing.

BENCH CLEANING: keeping benches suitable for sitting

LITTER REMOVAL: incidental litter collection and disposal

All work is to be performed in accordance with current recommendations or requirements of:

- **Charlotte County Government**
- **Florida Department of Agriculture and Consumer Services/Division of Plant Industry; Bureau of Entomology and Pest Control**
- **Florida Department of Environmental Protection**
- **Florida Department of Natural Resources**
- **Florida Department of Transportation**
- **Florida Irrigation Society**
- **Florida Nursery Growers and Landscape Association**
- **Florida Pest Management Association**
- **Florida Turf Grass Association**
- **International Society of Arboriculture**